



IMI CORNELIUS INC.
One Cornelius Place
Anoka, MN 55303-6234
Telephone (800) 238-3600
Facsimile (612) 422-3246

BEVERAGE DISPENSING SUPPORT SYSTEM ASSEMBLY (MODEL NO. 2232MS) INSTALLATION AND SERVICE MANUAL

**MANUFACTURED
BY
IMI CORNELIUS INC.
ANOKA, MINNESOTA 55303-1592**

BEVERAGE CONTROL PANEL ASS'Y

Manual Part No. 0713
June 5, 1991
Revised: April 23, 1992
Control Code A

THIS DOCUMENT CONTAINS IMPORTANT INFORMATION

This Manual must be read and understood before the installation and operation of this Equipment.

GENERAL DESCRIPTION

Warranty Registration Data (to be filled out by customer)
Model Number;
Serial Number;
Install Date;
Local Authorized Service Center;

GENERAL WARRANTY POLICY

IMI Cornelius Inc; warrants that all equipment and parts are free from defects in material and workmanship under normal use and service, AS MORE EXPRESSLY DEFINED AND LIMITED BY SPECIFIC WARRANTIES COVERING EACH PRODUCT.

TERMS AND CONDITIONS

PRICES...All prices are F.O.B. factory. Taxes imposed by any present or future federal, state or local laws, if paid by us, will be charged to purchaser. Title and risk of loss to equipment pass to purchaser upon delivery to carrier.

TERMS...Terms of net thirty (30) days from date of invoice will be gladly extended to those customers of known and acceptable financial standing. Otherwise, orders must be accompanied by cash. A service charge of 11/2% per month, which is an effective annual percentage rate of 18%, will be charged for invoices not paid within thirty days, but in no event will the monthly service charge exceed 1/12 of the annual percentage rate allowable under applicable state laws.

RETURNED GOODS...Merchandise must not be returned without prior approval or consent, which will be given or withheld at our sole discretion. **(All returned merchandise must be sent freight prepaid to IMI Cornelius Inc; Anoka, Minnesota).** If the merchandise is in a new, unused condition and is in its original carton with all the original packing and is a configuration appearing in our current catalog, it will be accepted back (subject to prior approval as stated above) and a credit allowed amounting to the original selling price or current selling price, whichever is lower, less the restocking charge indicated below.

<p>If returned goods are received by Cornelius: Within 60 days of invoice date — 10% of applicable selling price. Within 61–120 days of invoice date — 20% of applicable selling price. Over 120 days of invoice date — 30% of applicable selling price.</p>
--

Shipments of returned merchandise sent collect will not be accepted. Used or discontinued equipment will not be accepted for credit under any circumstances. Item returned to IMI Cornelius Inc; for credit or reimbursement, having a value of less the 25.00 dollars will not receive credit.

CLAIMS...In the event of shortage, notify carrier as well as us immediately. In the event of damage, notify carrier. We are not responsible for damage occurring in transit, but will gladly render assistance necessary to pursue your claim. Merchandise must be inspected for concealed damage within 15 days of receipt.

ORDERING INFORMATION

Please check the part numbers carefully when ordering. Be sure to include: Quantity, Part. No. Description, and How to Ship—if you have specific routing plans.

Note: quantity prices may be available on spare parts. Save money by ordering larger quantities or bulk packaging on specific items shipped from Anoka.

Compare quality, performance and prices. Then consolidate and simplify your ordering procedure by ordering current service parts from IMI Cornelius Inc; located nearest to your area.

To reduce processing and shipping time please submit separate orders for service parts, rather than combine orders with equipment.

SHIPPING INFORMATION

Unless otherwise instructed, all merchandise will be shipped as follows:

0–150 Lbs. (0–68 KG) United Parcel Service

Over 150 Lbs. (68 KG) Truck

Cornelius shall select point of origin for shipments to give the most efficient service. Freight charges are from manufacturing point.

COMPLETE SERVICE

Your trained Cornelius Sales Person stands ready to serve you with ordering and technical assistance. He can also offer you success proven merchandising ideas and placement programs that will help you to locate Cornelius beverage equipment in retail accounts. Complete repair and installation service by factory trained personnel is available at Authorized Service Centers. Addresses are available at your request. Spare parts may also be ordered from our Authorized Service Centers.

HOME OFFICES AND MANUFACTURING

IMI Cornelius Inc.

One Cornelius Place
Anoka, Minnesota 55303-1592
(612) 421-6120
800-238-3600
FAX (612) 422-3255

Our 800 number access' the nearest Distribution Center for sales assistance.

DISTRIBUTION CENTERS

NORTHWEST:

IMI Cornelius Inc.

One Selina Drive
Albany, New York 12205
(518) 869-6606
FAX 518-869-9038
800-238-3600

SOUTHEAST:

IMI Cornelius Inc.

6150-D LaGrange Blvd.
Atlanta, Georgia 30336
(404) 349-0412
FAX 404-346-7054
800-238-3600

SOUTHWEST:

IMI Cornelius Inc.

7427 Tower
Ft. Worth, Texas 76118
(817) 654-3888
FAX 817-590-9639
800-238-3600

WEST:

IMI Cornelius Inc.

2089 Burroughs Avenue
San Leandro, California 94577
(510) 351-0961
FAX 510-351-2623

TABLE 1. SPECIFICATIONS

Model Numbers (Standard Assemblies W/O Optional Kits)

Domestic Units:

Beverage Control Panel (one carbonator) Requiring Connection to one Post-Mix Dispenser	1416
Beverage Control Panel (two carbonator) Requiring Connection to Two Post-Mix Dispenser	0516

Export Units:

Beverage Control Panel (one carbonator) Requiring Connection to One Post-Mix Dispenser	1548
Beverage Control Panel (two carbonator) Requiring Connection to Two Post-Mix Dispenser	0187

Overall Dimension:

Width	50.5 inches (12.827 M)
Height	91 inches (23.114 M)
Depth	19.5 inches (495.3 MM)

Shipping Weights (approximate):

Beverage Control Panel (one carbonator)	363 Pounds (164.7 KG)
Beverage Control Panel (two carbonator)	395 Pounds (179.17 KG)

Water Pressure Requirements (see note) 45 to 75–PSI (3.10 to 5.17 BARS)

Ambient Operating Temperature 40F (4.44C) to 100F (37.8C)

Carbonators Electrical Requirements:

Domestic:

Operating Voltage	115VAC, 60HZ
Current Draw	6.8 Amps

Export:

Operating Voltage	230VAC, 50 HZ
Current Draw	3.3 Amps

Note: If plain water source pressure is above 75–PSI (5.17 Bars), optional Water Pressure Regulator Kit must be installed and adjusted to 75–PSI (5.17 Bars). If water source pressure is consistently less than 45–PSI (3.10 Bars), the Optional Water Pressure Booster Kit must be installed in the system. The Booster Kit will boost water pressure from 50 to 70–PSI (3.45 to 4.83 Bars).

INSTALLATION

This manual is intended to assist the installer and service personnel in the installation, operation, and maintenance procedures to be performed on the Beverage Control Panel Assembly (see Figure 1 and applicable Figure 3, 4, 5, or 6).

The Beverage Control Panel Assembly is designed to filter, pressure regulator, and distribute plain and carbonated water, CO₂ gas, and syrup to the Post-Mix Beverage Dispenser or dispensers and various other equipment connected to the system.

NOTE: The Beverage Control Panel Assembly is manufactured in America and has American sizes on the hardware. All metric conversion are approximate and vary in size.

NOTE: The Beverage Control Panel Assembly was thoroughly inspected before leaving the factory and the carrier has accepted and signed for it. Any damage or irregularities should be noted at the time of delivery (or not later than 15 days from date of deliver) and immediately reported to the delivering carrier. Request a written inspection report from Claims Inspector to substantiate any necessary claim. File claim with the delivering carrier, not with IMI Cornelius Inc.

INSTALLING POST-MIX DISPENSER(S)

Refer to manual(s) provided with the Post-Mix Dispenser(s) for installation instructions, then install Dispenser(s) in operating location(s).

INSTALLING BEVERAGE CONTROL PANEL ASSEMBLY

Your Beverage Control Panel Assembly may be equipped with one or more of the optional kits as shown in Figure 2. Figure 1 shows the standard Beverage Control Panel Assembly with no optional kits and Figure 2 shows the panel assembly with optional kits installed.

NOTE: A dedicated and properly grounded electrical outlet with proper electrical requirements must be located close to the Beverage Control Panel Assembly installation location to provide electrical power to (depending upon Beverage Control Panel Model Number) one or two carbonators.

If your Beverage Control Panel Assembly is equipped with either or both the optional air compressor kit or the water pressure booster kit, dedicated properly grounded electrical outlets with proper electrical requirements must also be located close to the Beverage Control Panel Assembly installation location to provide electrical power.

No other electrical equipment should be connected to these electrical circuits. ALL ELECTRICAL WIRING MUST CONFORM TO NATIONAL AND LOCAL ELECTRICAL CODES.

Table 2. Loose-Shipped Parts

Item No.	Part No.	Name	Qty.
1	300894-000	Water Surge Tank	1
2	300893-000	Strap, Surge Tank	1
3	300912	Tube Ass'y, .375 I.D. By 56-in long	1
4	311304	Tapered Gasket, Black	4
5	0590	Elbow Ass'y, Surge Tank	1

INSTALLING WATER SURGE TANK (ITEM 1) ON BEVERAGE CONTROL PANEL ASSEMBLY

NOTE: It is suggested for ease of assembly, that the loose-shipped WATER SURGE TANK (item 1) be installed on the Beverage Control Panel Assembly upper frame before the Panel Assembly is set upright and fastened to the wall.

1. Install ELBOW ASS'Y SURGE TANK (item 5) in top of WATER SURGE TANK (item 1) as shown in Figure 17. Seal pipe thread connection with pipe sealing compound.
2. Refer to applicable Figure 1 or 2 for water surge tank location on Beverage Control Panel Assembly upper frame, then remove two self-drilling screws from frame.
3. Position water surge tank in position on Beverage Control Panel Assembly.
4. Place STRAP, SURGE TANK (item 2) in position around water surge tank and align holes in strap with holes in frame where two self-drilling screws were removed.
5. Secure strap to frame with two self-drilling screws removed in step 2) preceding.

6. Connect one end of TUBE ASS'Y (item 33) to water surge tank elbow assembly 3/8–inch flare (5/8–18) fitting as shown in applicable Figure 3, 4, 5, or 6. Seal connection with TAPERED GASKET, BLACK (item 4).
7. Connect other end of tube assembly to water manifold assembly 3/8–inch flare (5/8–18) fitting on water filter assembly (see applicable Figure 3, 4, 5, or 6). Seal connection with TAPERED GASKET, BLACK (item 4).

FASTENING BEVERAGE CONTROL PANEL ASSEMBLY TO WALL



WARNING: The Beverage Control Panel Assembly must be securely fastened to the wall before connecting the assembly into the system. The Beverage Control Panel Assembly must be fastened to the wall with six fasteners provided by the Installer) and each fastener must be capable of resisting a 200 pound (90.7 KG) pull. Be very careful when handling the assembly as it is very top heavy and could fall and cause serious personal injury and also equipment damage.

Refer to instructions in previous WARNING note and secure Beverage Control Panel Assembly to wall as follows:

1. Very carefully, lay panel assembly upper frame over on its back side. Slide telescoping lower frame up on panel assembly upper frame.
2. Very carefully, lift Beverage Control Panel Assembly up and place in position up against wall.
3. Using screw adjusters on bottoms of Legs, adjust until Control Panel Assembly sits level.
4. Secure Control Panel Assembly to wall with six fasteners provided by the installer.
5. Using .156 I.D. tubing provided in installation kit, connect one end of tubing to vented double check valve (see applicable Figure 3, 4, 5, or 6), then route other end of tubing to a permanent floor drain.
6. Fasten tubing to frame assembly with wire ties provided in installation kit.

CONNECTING SUGAR–BASE SYRUP TANKS CO₂ LINES TO BEVERAGE CONTROL PANEL ASSEMBLY CO₂ MANIFOLD

(see Figure 7)

1. Using .265 I.D. tubing, fittings, gas quick disconnects, and tubing clamps, provided in the installation kit, make up three gas lines to be connected between the CO₂ manifold and the sugar–base syrup tanks.
2. Connect three gas lines swivel nut ends to CO₂ check valves on Beverage Control Panel Assembly CO₂ manifold. Seal connections with white tapered gaskets.

CONNECTING DIET SYRUP TANK CO₂ LINE TO BEVERAGE CONTROL PANEL ASSEMBLY DIET SYRUP CO₂ REGULATOR.

(see Figure 7)

3. Using .265 I.D. tubing, fittings, gas quick disconnect, and tubing clamps, make up one gas line to be connected between the Beverage Control Panel Assembly diet–syrup tank.
4. Connect swivel nut end of gas line to check valve on outlet of the diet–syrup tank CO₂ regulator. Seal connection with white tapered gasket.

CONNECTING BEVERAGE CONTROL PANEL ASSEMBLY TO POST–MIX DISPENSER(S) AND OTHER EQUIPMENT TO BE CONNECTED TO THE SYSTEM

(see Figure 7)

NOTE: The syrup, plain and carbonated water and CO₂ lines to the Post–Mix Dispenser(s) and various other equipment at the installation site may be routed overhead or through a floor chase from the Beverage Control Panel Assembly. MAKE SURE ALL LINES ARE LABELED FOR IDENTIFICATION.

Refer to manual(s) provided with the Post–Mix Dispenser(s) to connect plain water, carbonated water, and syrup lines to the Dispenser(s).

Center–Island Installation with Optional Syrup Tanks Hookup (see Figure NO TAG)

Connect CO₂, plain water, carbonated water, and syrup lines between Beverage Control Panel Assembly, the Post–Mix Dispenser, and other equipment to be connected to the system. Optional syrup tanks Kit (P/N 0673) is used to connect four syrup tanks into system.

Connect insulated plain water line between plain water line connected to Post–Mix Dispenser cold plate and the Orange Juice Dispenser.

Center–Island and Second Dispenser Installation with Optional Syrup Tanks Hookup (see Figure NO TAG)

Connect CO₂, plain water, carbonated water, and syrup lines between Beverage Control Panel Assembly, the Post–Mix Dispensers, and other equipment to be connected to the system. Optional Syrup Tanks Kit (P/N 0673) is used to connect four syrup tanks into the system.

Connect insulated plain water line between plain water line connected to Post–Mix Dispenser cold plate and the Orange Juice Dispenser.

Center–Island Installation with Bulk Syrup Tank Hookup (see Figure NO TAG).

Connect CO₂, plain water, carbonated water, and syrup lines between Beverage Control Panel Assembly, the Post–Mix Dispenser, and other equipment to be connected to the system.

Connect insulated plain water line between plain water line connected to Post–Mix Dispenser cold plate and the Orange Juice Dispenser.

Center–Island and Second Dispenser Installation with Bulk Syrup Tank Hookup (see Figure NO TAG).

Connect CO₂, plain water, carbonated water and syrup lines between Beverage Control Panel Assembly, the Post–Mix Dispensers, and other equipment to be connected to the system.

Connect insulated plain water line between plain water line connected to Post–Mix Dispenser cold plate and the Orange Juice Dispenser.

PREPARATION FOR OPERATION

BEVERAGE CONTROL PANEL ASSEMBLY

NOTE: The Beverage Control Panel Assembly must be connected to a water source with water pressure between 45 and 75–PSI (3.10 and 5.17 Bars). If water pressure is over 75–PSI (5.17 Bars), an **Optional Water Pressure Regulator Kit (P/N 300919–00)** must be installed. If plain water source is below 45–PSI (3.10 Bars), an **Optional Water Pressure Booster Kit** must be installed in the system to boost water pressure to 75–PSI (5.17 Bars).

IMPORTANT: DO NOT operate (if applicable) the **Optional Water Pressure Booster water pump** with no water connected to the Beverage Control Panel Assembly. Operating water pump dry will void its factory warranty.

1. Install loose–shipped water filter cartridges on water filter assembly.

2. Make sure all shutoff valves on water manifold assembly and water filter assembly are in “OFF” position.

IMPORTANT: DO NOT operate carbonator(s) water pump(s) or water pressure booster system (if applicable) water pump with no water in the system. Operating pumps dry will cause damage to the pumps which will void their factory warranty.

3. Connect plain water source line, meeting requirements of preceding NOTE, to Beverage Control Panel Assembly.
4. Open Beverage Control Panel Assembly plain water source shutoff valve.
5. Beverage Control Panel Assembly equipped with Everpure water filters (see applicable Figure 3 or 5).
 - A. Connect length of garden hose to FILTER “ACTIVATION VALVE,” then route hose to a permanent drain.
 - B. Open “ACTIVATION VALVE” and allow approximately 28–gallons of water to flow through the water filters, then close valve.
6. Standard Installation (see Figure 7).



WARNING: CO₂ Displaces Oxygen. Strict Attention *must* be observed in the prevention of CO₂ (carbon dioxide) gas leaks in the entire CO₂ and soft drink system. If a CO₂ gas leak is suspected, particularly in a small area, *immediately* ventilate the contaminated area before attempting to repair the leak. Personnel exposed to high concentration of CO₂ gas will experience tremors which are followed rapidly by loss of consciousness and suffocation.

Connect bulk CO₂ tank CO₂ supply line to barbed fitting on CO₂ manifold. Secure connection with tubing clamp.

Installation employing the optional high–pressure CO₂ Regulator Assembly Kit (P/N 0708) (see Figure 7)



WARNING: To avoid personal injury and/or property damage, always secure CO₂ cylinders with safety chain to prevent them from falling over. Should the valve become accidentally damaged or broken off, CO₂ cylinder can cause serious personal injury.

- A. Locate two full CO₂ cylinders in upright positions next to the CO₂ mounting bracket. Fasten CO₂ cylinders with safety chain.
- B. Connect two CO₂ lines from Beverage Control Panel Assembly two primary CO₂ regulators to the CO₂ cylinders.

7. Installation employing the Optional Water Pressure Booster System Kit (see applicable Figure 3, 4, 5, or 6)

Note service valve on bottom of the Water Pressure Booster System Water Tank. The water tank must be pressurized with 40 5–PSI (2.76 .34 Bars) of commercially dry air, CO₂, or nitrogen gas through the water tank service valve before putting system into operation.

8. Water Surge Tank (see applicable Figure 3, 4, 5,, or 6)

Note service valve on bottom of the water surge tank. The water surge tank must be pressurized with 12 2–PSI (.83 .14 Bars) of commercially dry air, CO₂, or nitrogen gas through the water tank service valve before putting system into operation.

9. System Connected to Bulk CO₂ Supply (see Figure 7)

- A. Open shutoff valve on bulk CO₂ tank.
- B. Adjust CO₂ regulator on bulk CO₂ tank to 105–PSI (7.24 Bars). Pull up on carbonators tanks relief valves for approximately two seconds to bleed air from tanks.
- C. Adjust sugar–base syrup tanks CO₂ regulator with 100–PSI (6.9 Bars) gauge on secondary CO₂ regulator assembly to 60–PSI (4.14 Bars).
- D. Adjust diet syrup tank CO₂ regulator with 30–PSI (2.07 Bars) gauge on secondary CO₂ regulator Assembly to 12–PSI (.83 Bars).

10. System connected to two fifty pound CO₂ cylinders (see Figure 7).

- A. Open CO₂ cylinders valves slightly to allow lines to slowly fill with gas, then open valves fully to back seat valve. Back–seating valve prevents leakage around valve shaft.

- B. Adjust two Primary CO₂ regulators to 105–PSI (7.24 Bars). Pull up on carbonator(s) tank(s) relief valve(s) for approximately two seconds to bleed air from tanks.
- C. Adjust secondary CO₂ regulator assembly CO₂ regulator with 100–PSI (6.9 Bars) gauge for sugar–base syrup tanks to 60–PSI (4.14 Bars).
- D. Adjust diet syrup tank CO₂ regulator with 30–PSI (2.07 Bars) gauge on secondary CO₂ regulator assembly to 12–PSI (.83 Bars).

11. The Post–Mix Dispenser(s) and entire syrup systems should be sanitized as instructed in manual(s) provided with Dispenser(s) before syrup is connected into the systems.

IMPORTANT: Even though sanitizing procedure has been performed on syrup systems during initial installation a temporary new tubing plastic off–taste of dispensed product may occur. If this off–taste should occur, prepare a solution of citric acid in proportion as instructed on the citric acid packaging. Pump citric acid solution through the syrup systems and all carbonated and plain water tubes installed as part of the system. Thoroughly flush syrup systems and all carbonated and plain water tubes with plain water to make sure all citric acid has been removed.

- 12. Open all plain water shutoff valves on Beverage Control Panel Assembly.
- 13. Check entire system for syrup, CO₂ gas, and plain and carbonated water leaks. Repair if leaks are evident.
- 14. Plug carbonator(s) and Water Pressure Booster system (if applicable) power cords into electrical outlets.
- 15. If Optional Air Compressor Kit is being used and it is desired to operate with compressed air rather than CO₂ gas pressure.
 - A. Plug air compressor power cord into electrical outlet.
 - B. Place CO₂/air switchover valve (see Figure 7) in air position.
- 16. Refer to manual(s) provided with the Dispenser(s) to put Dispenser(s) into operation. Operate all dispensing valves to bleed all air from plain and carbonated water systems.
- 17. Standard Installation Connected to Bulk Syrup Tanks (see Figure 7)

- A. Connect bulk syrup tank into system.
 - B. Connect three other flavors syrup tanks into syrup systems.
18. Installation Using Optional Syrup Tank Kit (P/N 0673) (see Figure 7.)
- A. Connect four syrup tanks into syrup systems.
 - B. Connect three other flavors syrup tanks into syrup systems.
19. Operate all Dispenser(s) dispensing valves to bleed all air from syrup systems.

CHECKING ENTIRE SYSTEM FOR SYRUP, CO₂ GAS, AND PLAIN AND CARBONATED WATER LEAKS

Check entire system for syrup, CO₂ gas, and plain and carbonated water leaks and repair if evident.

SEALING ENDS OF FLOOR CHASE (IF APPLICABLE)

1. Pack ends of floor chase with paper to within approximately six-inches from the top.
2. Seal ends of floor chase with plaster of paris which may be purchased at a local building materials store.

*BEVERAGE CONTROL PANEL MODEL 0817 AND 0516 ARE EQUIPPED WITH TWO CARBONATOR ASSEMBLIES. MODEL 1416 AND 1548 ARE EQUIPPED WITH ONE CARBONATOR ASSEMBLY.

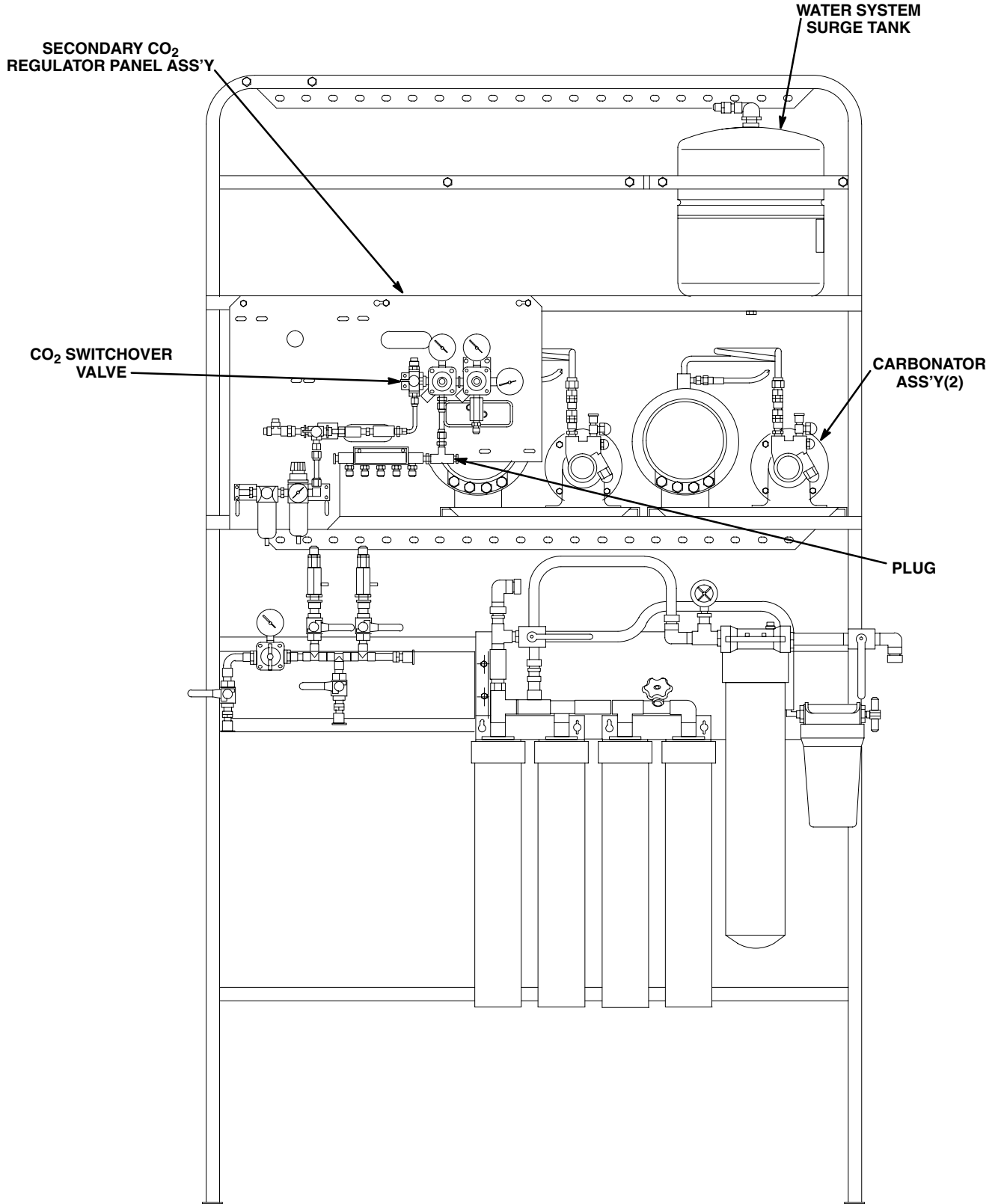
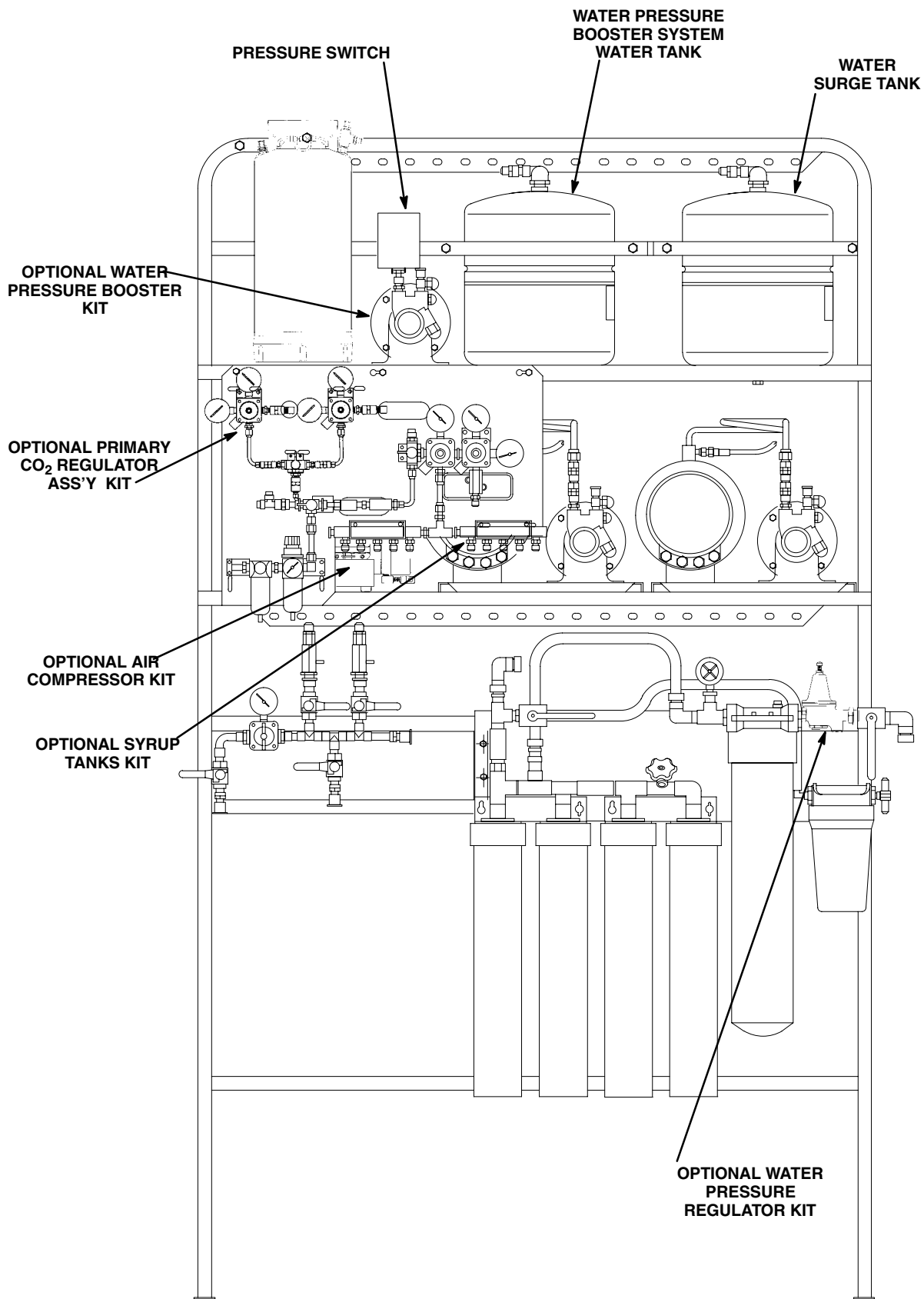
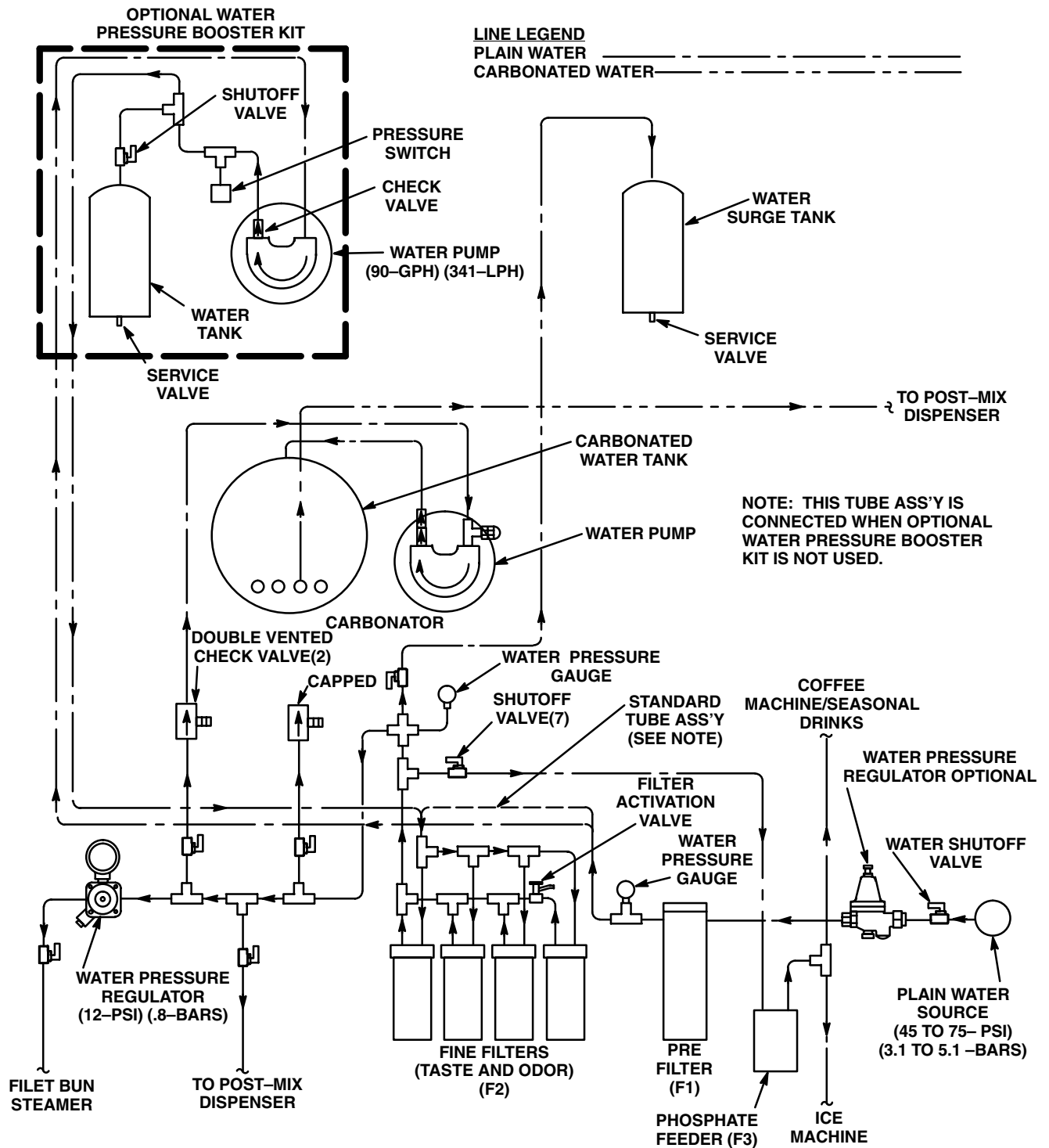

FIGURE 1. STANDARD BEVERAGE CONTROL PANEL ASS'Y



**FIGURE 2. BEVERAGE CONTROL PANEL ASSEMBLY
(WITH ALL OPTIONAL KITS INSTALLED)**



**FIGURE 3. PLAIN AND CARBONATED WATER SYSTEMS FLOW DIAGRAM
 W/EVERPURE WATER FILTERS (MODELS 1416 AND 1548)**

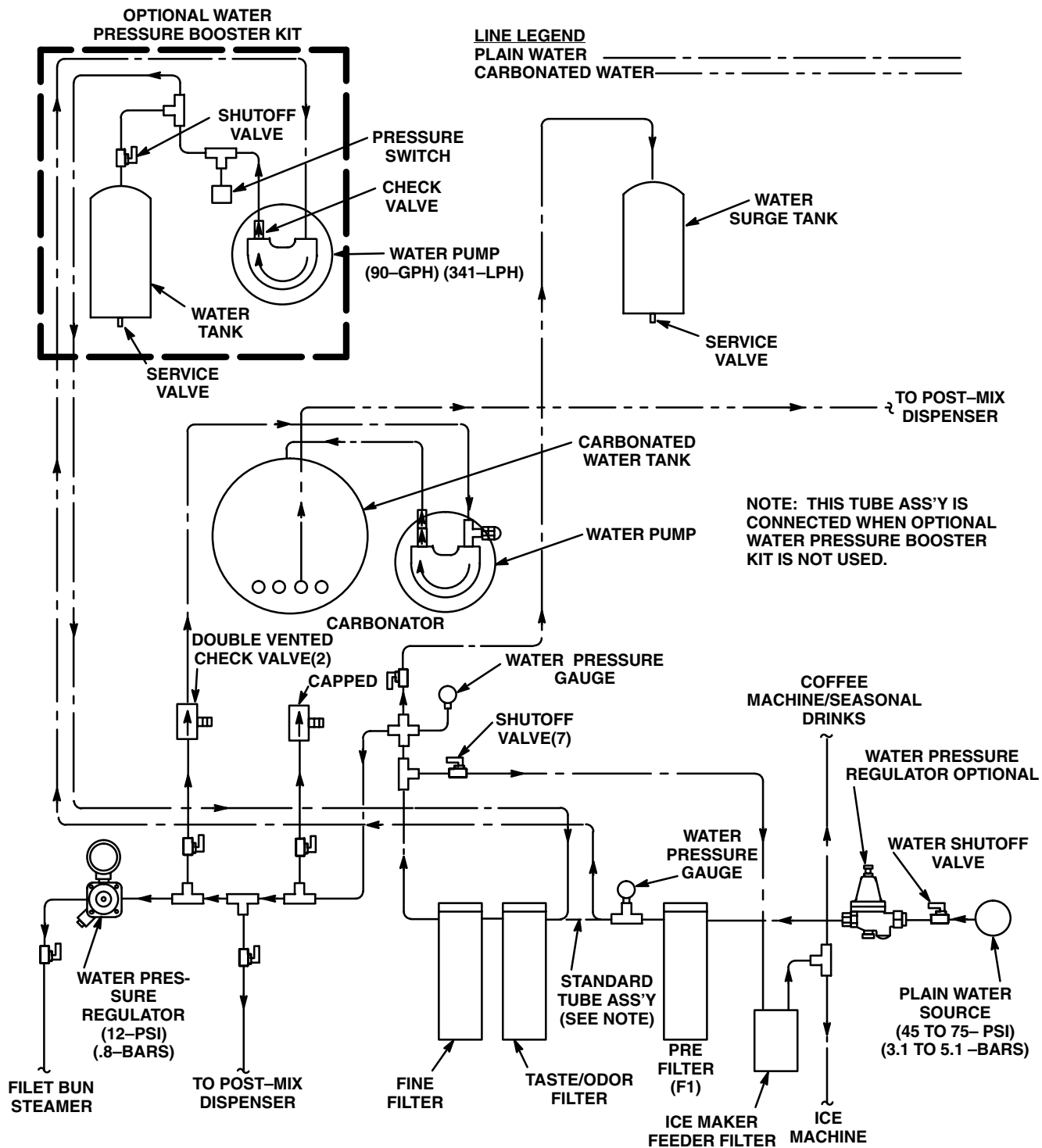

FIGURE 4. PLAIN AND CARBONATED WATER SYSTEMS FLOW DIAGRAM W/CUNO WATER FILTERS (MODELS 1416 AND 1548)

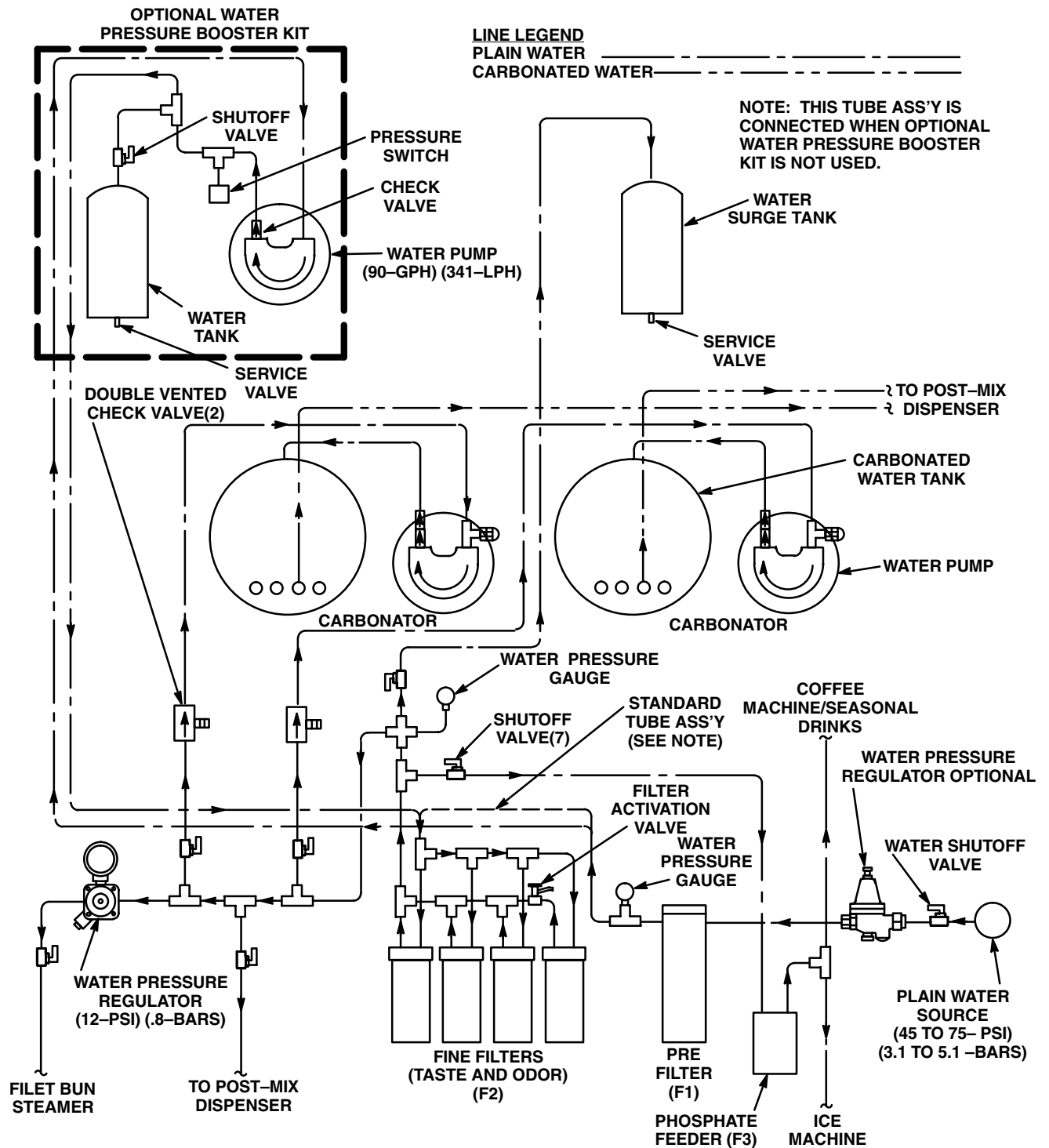

FIGURE 5. PLAIN AND CARBONATED WATER SYSTEMS FLOW DIAGRAM W/EVERPURE WATER FILTERS (MODELS 0187 AND 0516)

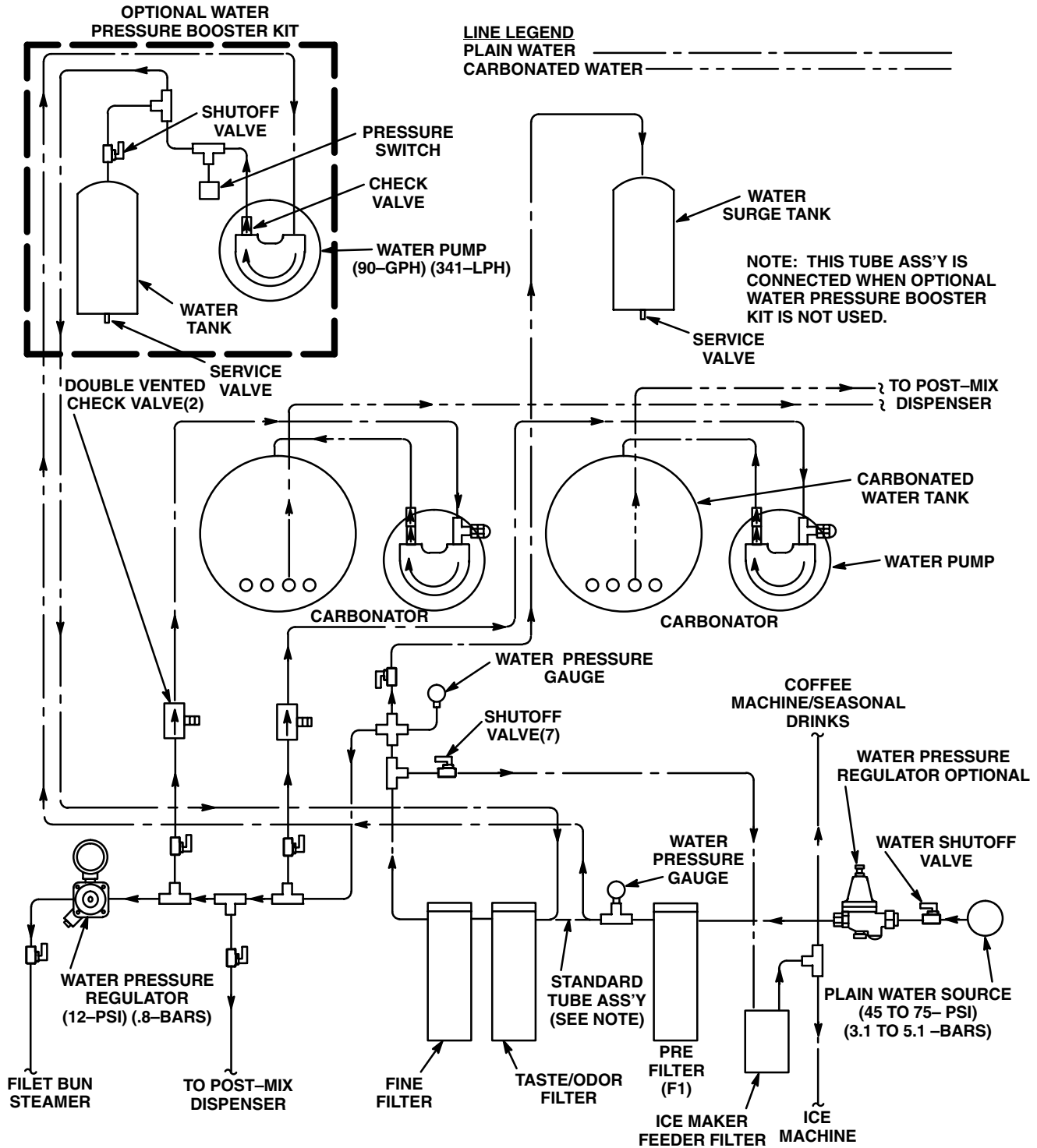

FIGURE 6. PLAIN AND CARBONATED WATER SYSTEMS FLOW DIAGRAM W/CUNO WATER FILTERS (MODELS 0187 AND 0516)

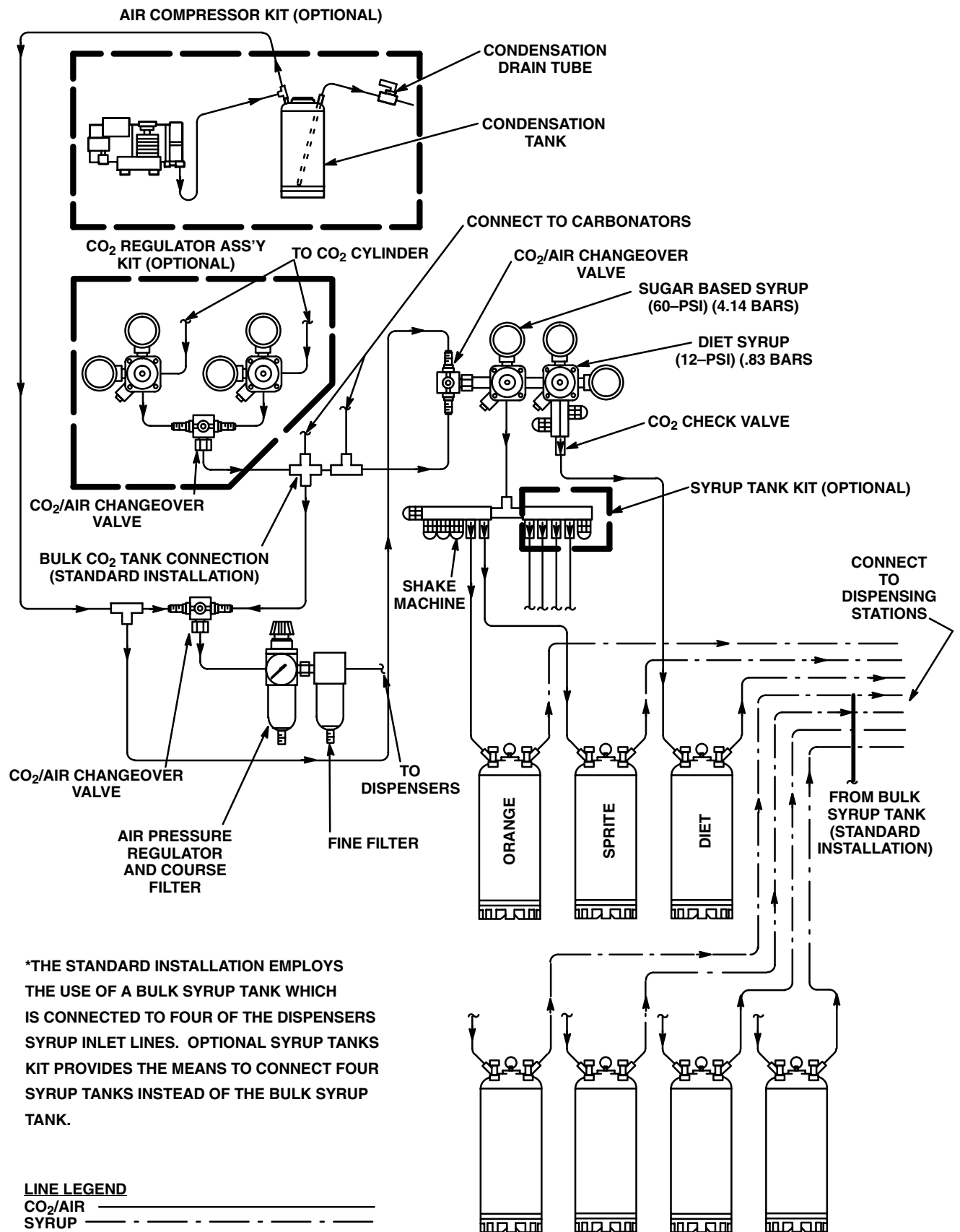

FIGURE 7. CO₂/AIR AND SYRUP SYSTEMS FLOW DIAGRAM

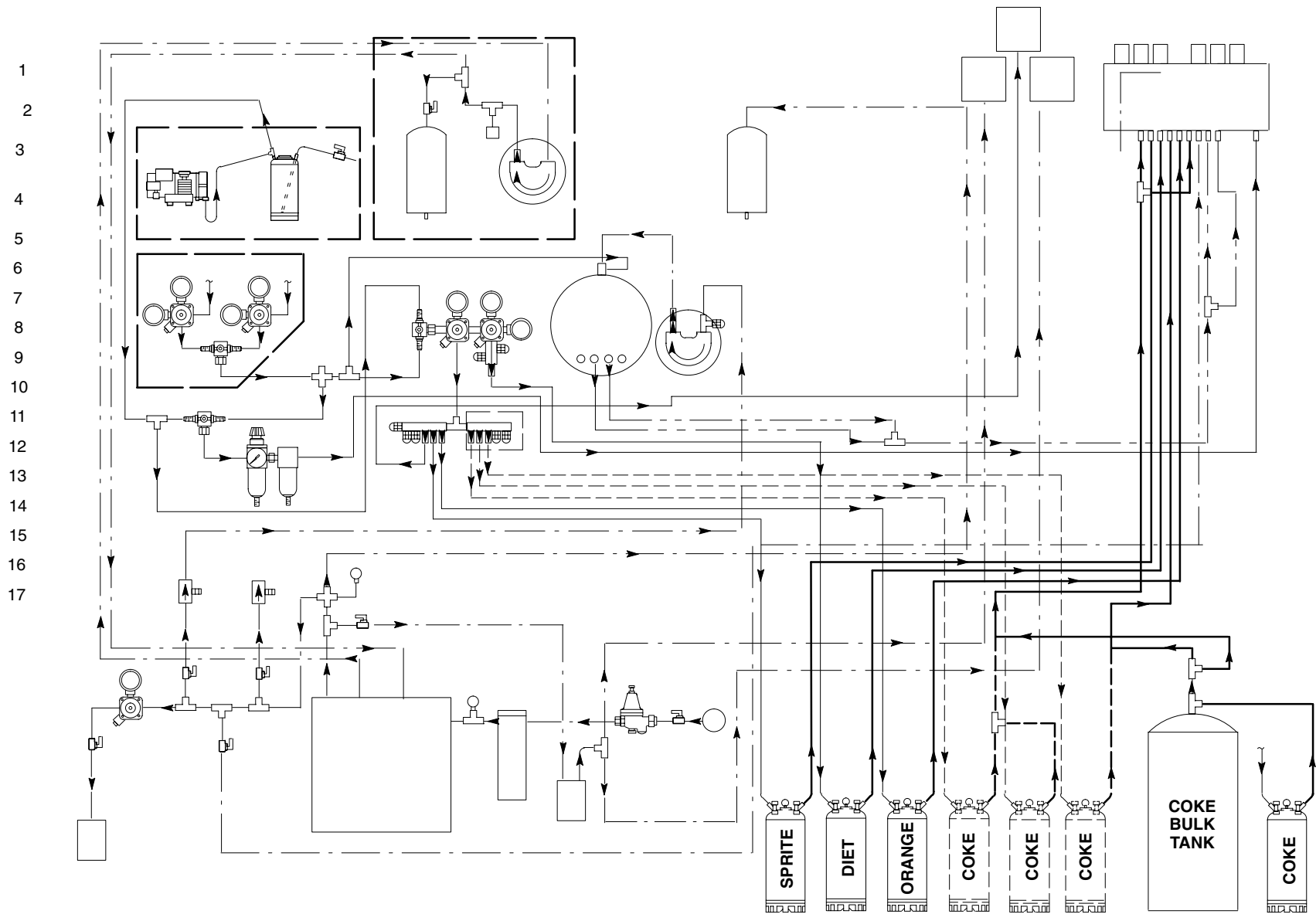

FIGURE 8. CONNECTION DIAGRAM (CENTER-ISLAND INSTALLATION WITH OPTIONAL SYRUP TANKS HOOKUP)

CONN NBR	Part No.	DESCRIPTION	QTY.
1	770409000	3/8 Swivel - 3/8 Barb Elbow	1
	311304000	Gasket	1
	309852000	170 Oeitker Clamp	2
2	770695000	1/2 x 3/8 x 3/8 Barb Tee	1
	309852000	170 Oeitker Clamp	4
	319681000	210 Oeitker Clamp	2
3	176206000	1/2 Nut	1
	176205000	1/2 x 3/8 Stem	1
	311304000	Gasket	1
	309852000	170 Oeitker Clamp	4
4	770105000	1/4 Swivel Hose Stem	1
	770101000	1/4 Swivel Nut	1
	111353000	145 Oeitker Clamp	2
	178025100	Gasket	1
5	770304000	1/4 x 3/8 Swivel Hose Stem	1
	770301000	3/8 Swivel Nut	1
	311304000	Gasket	1
	111353000	145 Oeitker Clamp	2
6	770699000	1/2 x 1/2 x 3/8 Barb Tee	2
	770423000	1/2 x 3/8 Barb Splice	1
	319681000	210 Oeitker Clamp	10
	309852000	170 Oeitker Clamp	6
7	770407000	3/8 x 1/4 Barb Splice	1
	309852000	170 Oeitker Clamp	4
	111353000	145 Oeitker Clamp	2
8	770607000	3/8 x 3/8 1/4 Barb Tee	1
	309852000	170 Oeitker Clamp	4
	111353000	145 Oeitker Clamp	2

CONN NBR	Part No.	DESCRIPTION	QTY.
9	770403000	3/8 x 3/8 Barb Splice	1
	309852000	170 Oeitker Clamp	4
10	770621000	3/8 x 1/4 x 1/4 Barb Tee	1
	309852000	170 Oeitker Clamp	2
	111353000	145 Oeitker Clamp	4
11		Installer Supplied	1
12	770305000	3/8 Swivel Hose Barb	1
	770301000	3/8 Swivel Nut	1
	309852000	170 Oeitker Clamp	2
	311304000	Gasket	1
13	274244000	Gas QD Slot 1/4 Barb	1
	111353000	145 Oeitker Clamp	2
14	274212000	Syrup QD 1/4 Flare	1
	770465000	1/4 Flare x 3/8 Barb	1
	309852000	170 Oeitker Clamp	2
15	770402000	1/4 x 1/4 Barb Splice	1
	111353000	145 Oeitker Clamp	4
16		Installer Supplied	
17	274212000	Syrup QD 1/4 Flare	1
	770465000	1/4 FFL x 3/8 Barb	1
	309852000	170 Oeitker Clamp	2
	311035000	Strainer	1
	770750010	1/4 MFL to 1/4 MPT	2
	310822000	1/4 FFL to 1/4 FFI	1
	178025100	Gasket	2

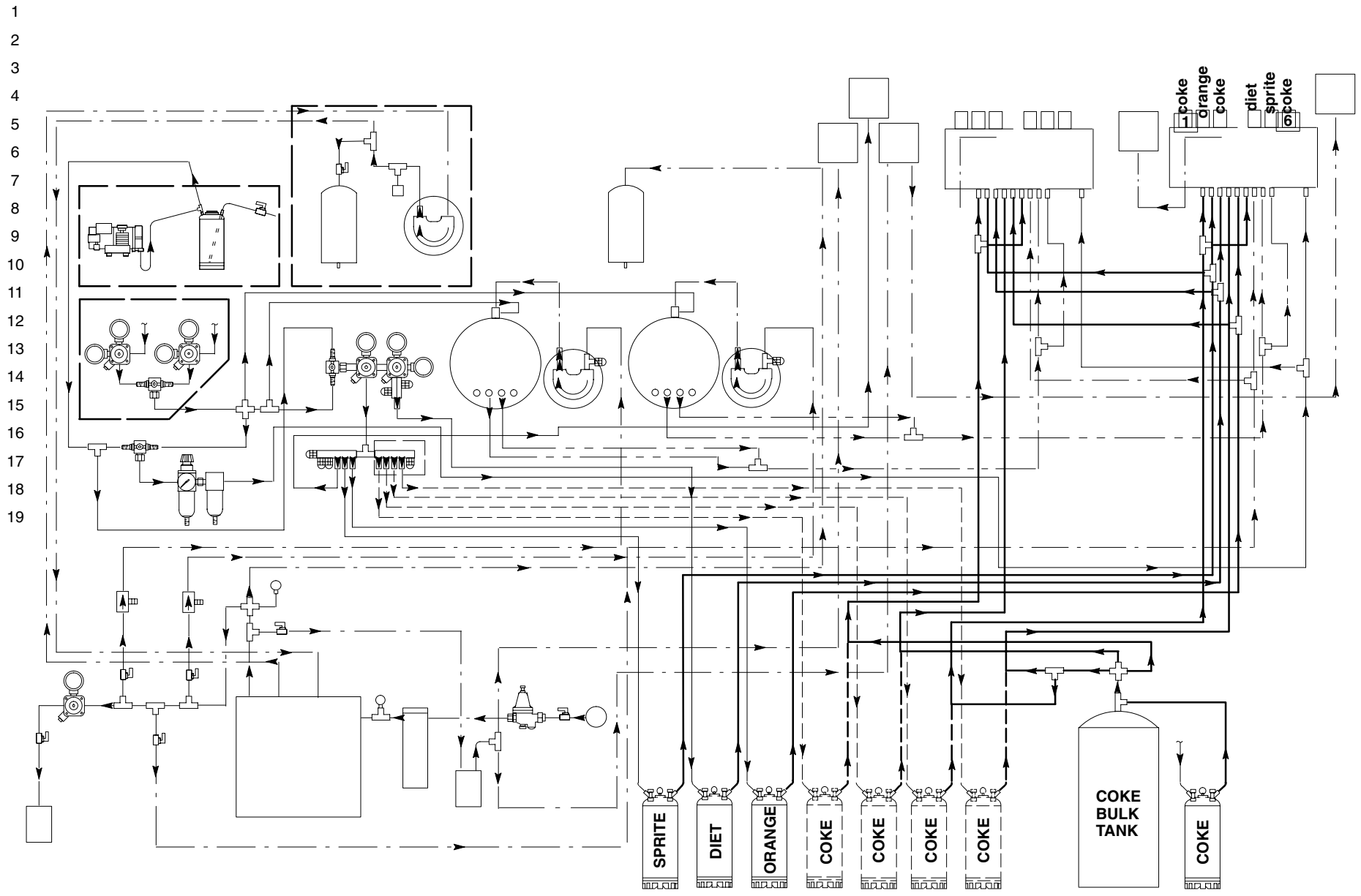

FIGURE 9. CONNECTION DIAGRAM (CENTER-ISLAND AND SECOND DISPENSER WITH OPTIONAL SYRUP TANKS HOOKUP)

CONN NBR	Part No.	DESCRIPTION	QTY.
1	770409000	3/8 Swivel -///8 Barb Elbow	1
	311304000	Gasket	1
	309852000	170 Oeitker Clamp	2
2	770695000	1/2 x 3/8 x 3/8 Barb Tee	1
	309852000	170 Oeitker Clamp	4
	319681000	210 Oeitker Clamp	2
3	176206000	1/2 Swivel Nut	1
	176205000	Swivel Barb	1
	311304000	Gasket	1
	309852000	170 Oeitker Clamp	2
4	770104000	1/4 Swivel Hose Stem	1
	176017000	1/4 Swivel Nut	1
	111353000	145 Oeitker Clamp	2
	178025100	Gasket	1
5	176271000	1/4 x 3/8 Swivel Hose Stem	1
	311242000	3/8 Swivel Nut	1
	311304000	Gasket	1
	111353000	145 Oeitker Clamp	2
6	770699000	1/2 x 1/2 x 3/8 Barb Tee	2
	770423000	1/2 x 3/8 Barb Splice	1
	319681000	210 Oeitker Clamp	10
	309852000	170 Oeitker Clamp	6
7	770407000	3/8 x 1/4 Barb Splice	1
	309852000	170 Oeitker Clamp	4
	111353000	145 Oeitker Clamp	2
8	770607000	3/8 x 3/8 x 1/4 Barb Tee	1
	309852000	170 Oeitker Clamp	4
	111353000	145 Oeitker Clamp	2

CONN NBR	Part No.	DESCRIPTION	QTY.
9	770403000	3/8 x 3/8 Barb Splice	1
	309852000	170 Oeitker Clamp	4
10	770621000	3/8 x 1/4 x 1/4 Barb Tee	1
	309852000	170 Oeitker Clamp	2
	111353000	145 Oeitker Clamp	4
11		Installer Supplied	1
12	176025000	3/8 Swivel Hose Barb	1
	311242000	3/8 Swivel Nut	1
	309852000	170 Oeitker Clamp	2
	311304000	Gasket	1
13	274244000	Gas QD Slot 1/4 Barb	1
	111353000	145 Oeitker Clamp	2
14	274212000	Syrup QD 1/4 Flare	1
	770465000	1/4 Flare x 3/8 Barb	1
	309852000	170 Oeitker Clamp	2
15	770699000	1/2 x 1/2 x 3/8 Barb Tee	1
	770423000	1/2 x 3/8 Barb Splice	1
	309852000	170 Oeitker Clamp	4
	319681000	210 Oeitker Clamp	6
16	770402000	1/4 x 1/4 Barb Splice	1
	111353000	145 Oeitker Clamp	4
17		Installer Supplied	
18	274212000	Syrup QD 1/4 Flare	1
	770465000	1/4 FFL x 3/8 Barb	1
	309852000	170 Oeitker Clamp	2
	311035000	Strainer	1
	770750010	1/4 MFL to 1/4 MPT	2
	310822000	1/4 FFL to 1/4 FFL	1
	178025100	Gasket	2

1
2
3
4
5
6
7
8
9
10
11
12
13
14
15
16
17
18

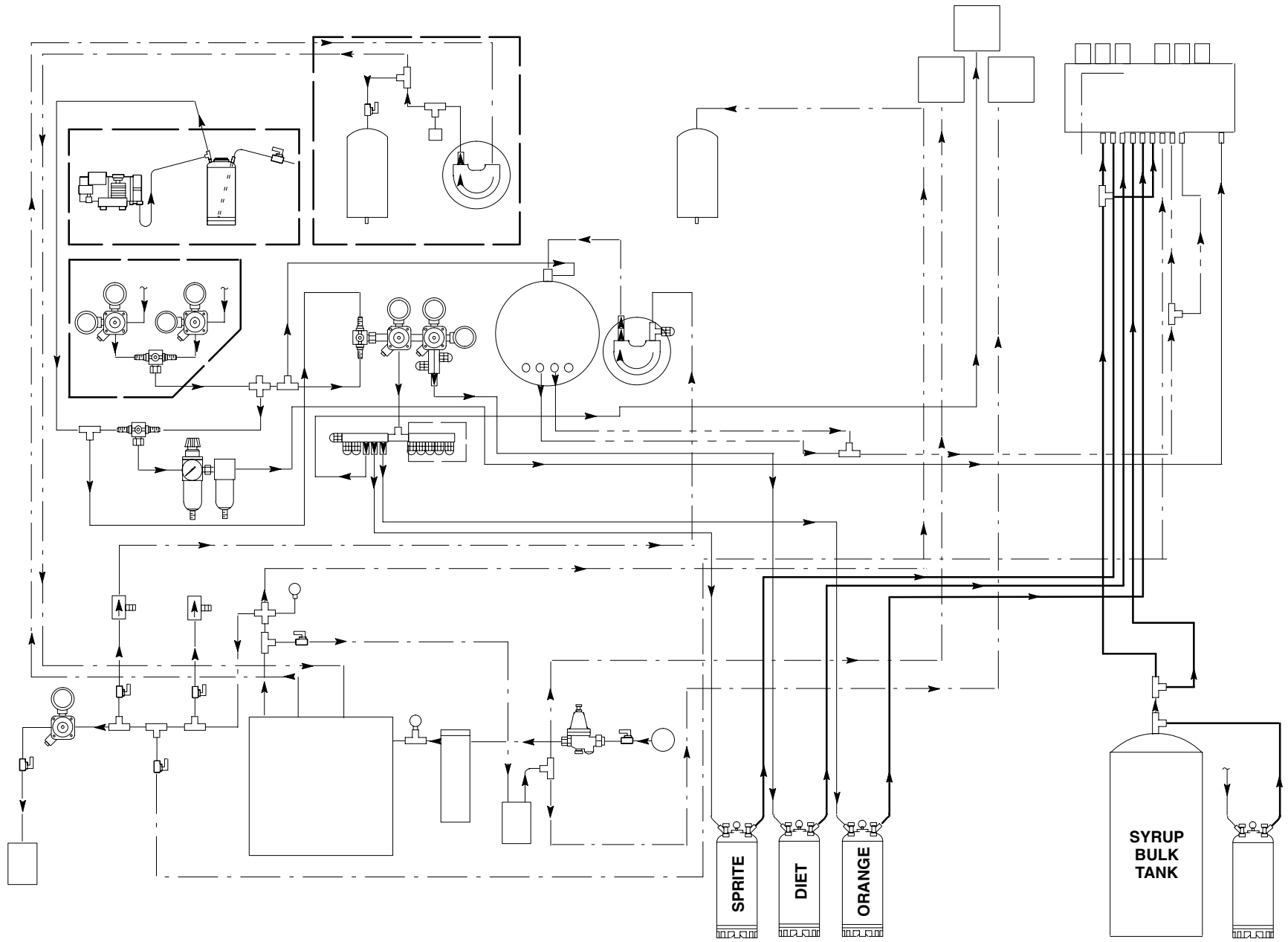

FIGURE 10. CONNECTION DIAGRAM (CENTER-ISLAND INSTALLATION WITH BULK SYRUP TANK HOOKUP)

CONN NBR	Part No.	DESCRIPTION	QTY.
1	770409000	3/8 Swivel -///8 Barb Elbow	1
	311304000	Gasket	1
	309852000	170 Oeitker Clamp	2
2	770695000	1/2 x 3/8 x 3/8 Barb Tee	1
	309852000	170 Oeitker Clamp	4
	319681000	210 Oeitker Clamp	2
3	176206000	1/2 Swivel Nut	1
	176205000	Swivel Barb	1
	311304000	Gasket	1
	309852000	170 Oeitker Clamp	2
4	770104000	1/4 Swivel Hose Stem	1
	176017000	1/4 Swivel Nut	1
	111353000	145 Oeitker Clamp	2
	178025100	Gasket	1
5	770304000	1/4 x 3/8 Swivel Hose Stem	1
	311242000	3/8 Swivel Nut	1
	311304000	Gasket	1
	111353000	145 Oeitker Clamp	2
6	770699000	1/2 x 1/2 x 3/8 Barb Tee	2
	770423000	1/2 x 3/8 Barb Splice	1
	319681000	210 Oeitker Clamp	10
	309852000	170 Oeitker Clamp	6
7	770407000	3/8 x 1/4 Barb Splice	1
	309852000	170 Oeitker Clamp	4
	111353000	145 Oeitker Clamp	2
8	770607000	3/8 x 3/8 x 1/4 Barb Tee	1
	309852000	170 Oeitker Clamp	4
	111353000	145 Oeitker Clamp	2
9	770403000	3/8 x 3/8 Barb Splice	1
	309852000	170 Oeitker Clamp	4

CONN NBR	Part No.	DESCRIPTION	QTY.
10	770621000	3/8 x 1/4 x 1/4 Barb Tee	1
	309852000	170 Oeitker Clamp	2
	111353000	145 Oeitker Clamp	4
11	770807020	1/2 Flare x 3/8 Barb Adapter	1
	309852000	170 Oeitker Clamp	2
	178025000	Gasket	1
12		Installer Supplied	1
13	176025000	3/8 Swivel Hose Barb	1
	311242000	3/8 Swivel Nut	1
	309852000	170 Oeitker Clamp	2
	311304000	Gasket	1
14	274244000	Gas QD Slot 1/4 Barb	1
	111353000	145 Oeitker Clamp	2
15	274212000	Syrup QD 1/4 Flare	1
	770465000	1/4 Flare x 3/8 Barb	1
	309852000	170 Oeitker Clamp	2
16	770402000	1/4 x 1/4 Barb Splice	1
	111353000	145 Oeitker Clamp	4
17		Installer Supplied	
18	770609000	3/8 x 3/8 x 3/8 Barb Tee	1
	309852000	170 Oeitker Clamp	6
19	274212000	Syrup QD 1/4 Flare	1
	770465000	1/4 FFL x 3/8 Barb	1
	309852000	170 Oeitker Clamp	2
	311035000	Strainer	1
	770750010	1/4 MFL to 1/4 MPT	2
	310822000	1/4 FFL to 1/4 FFL	1
	178025100	Gasket	2

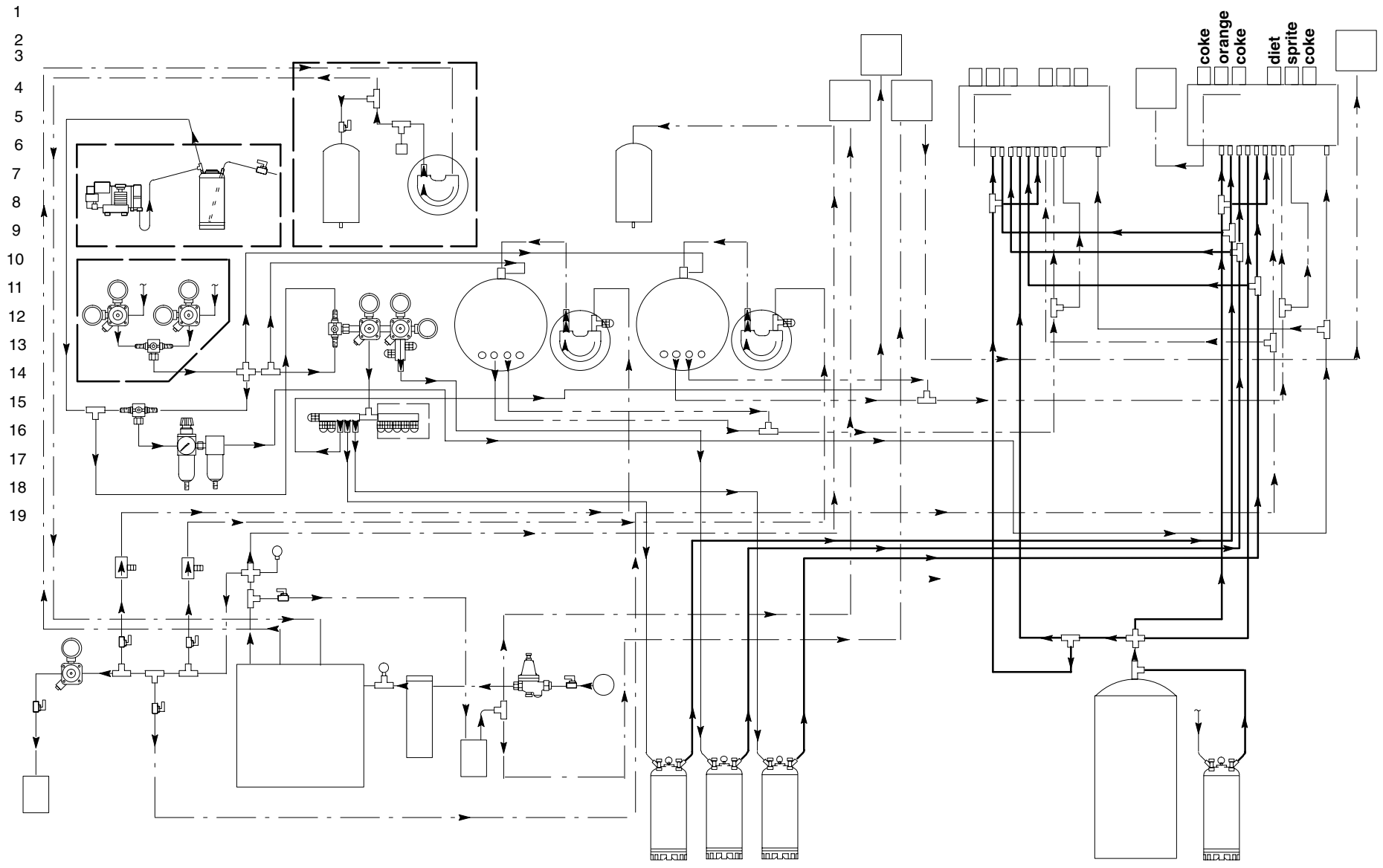

FIGURE 11. CONNECTION DIAGRAM (CENTER-ISLAND AND SECOND DISPENSER INSTALLATION WITH BULK SYRUP TANK HOOKUP)

CONN NBR	Part No.	DESCRIPTION	QTY.
1	770409000	3/8 Swivel -///8 Barb Elbow	1
	311304000	Gasket	1
	309852000	170 Oeitker Clamp	2
2	770695000	1/2 x 3/8 x 3/8 Barb Tee	1
	309852000	170 Oeitker Clamp	4
	319681000	210 Oeitker Clamp	2
3	176206000	1/2 Swivel Nut	1
	176205000	Swivel Barb	1
	311304000	Gasket	1
	309852000	170 Oeitker Clamp	2
4	770104000	1/4 Swivel Hose Stem	1
	176017000	1/4 Swivel Nut	1
	111353000	145 Oeitker Clamp	2
	178025100	Gasket	1
5	176271000	1/4 x 3/8 Swivel Hose Stem	1
	311242000	3/8 Swivel Nut	1
	311304000	Gasket	1
	111353000	145 Oeitker Clamp	2
6	770699000	1/2 x 1/2 x 3/8 Barb Tee	2
	770423000	1/2 x 3/8 Barb Splice	1
	319681000	210 Oeitker Clamp	10
	309852000	170 Oeitker Clamp	6
7	770407000	3/8 x 1/4 Barb Splice	1
	309852000	170 Oeitker Clamp	4
	111353000	145 Oeitker Clamp	2
8	770607000	3/8 x 3/8 x 1/4 Barb Tee	1
	309852000	170 Oeitker Clamp	4
	111353000	145 Oeitker Clamp	2
9	770403000	3/8 x 3/8 Barb Splice	1
	309852000	170 Oeitker Clamp	4

CONN NBR	Part No.	DESCRIPTION	QTY.
10	770621000	3/8 x 1/4 x 1/4 Barb Tee	1
	309852000	170 Oeitker Clamp	2
	111353000	145 Oeitker Clamp	4
11	770807020	1/2 Flare x 3/8 Barb Adapter	1
	309852000	170 Oeitker Clamp	2
	178025000	Gasket	1
12		Installer Supplied	1
13	176025000	3/8 Swivel Hose Barb	1
	311242000	3/8 Swivel Nut	1
	309852000	170 Oeitker Clamp	2
	311304000	Gasket	1
14	274244000	Gas QD Slot 1/4 Barb	1
	111353000	145 Oeitker Clamp	2
15	274212000	Syrup QD 1/4 Flare	1
	770465000	1/4 Flare x 3/8 Barb	1
	309852000	170 Oeitker Clamp	2
16	770699000	1/2 x 1/2 x 3/8 Barb Tee	3
	770423000	1/2 x 3/8 Barb Splice	1
	309852000	170 Oeitker Clamp	8
	319681000	210 Oeitker Clamp	14
17	770402000	1/4 x 1/4 Barb Splice	1
	111353000	145 Oeitker Clamp	4
18		Installer Supplied	
19	274212000	Syrup QD 1/4 Flare	1
	770465000	1/4 FFL x 3/8 Barb	1
	309852000	170 Oeitker Clamp	2
	311035000	Strainer	1
	770750010	1/4 MFL to 1/4 MPT	2
	310822000	1/4 FFL to 1/4 FFL	1
	178025100	Gasket	2

SERVICE AND MAINTENANCE

POST-MIX DISPENSER SERVICE AND MAINTENANCE

Refer to manual provided with the Post-Mix Dispenser for service and maintenance instructions.

BEVERAGE CONTROL PANEL ASSEMBLY SERVICE AND MAINTENANCE

CARBONATOR ASSEMBLY SERVICE AND MAINTENANCE

 **WARNING:** The carbonator water pump water inlet strainer screen and liquid double check valve must be inspected and service at least once a year under normal circumstances, and after any disruptions (plumbing work, earthquake, etc.) to the water supply system that might cause turbulent (erratic) flow of water through the system. A carbonator water pump with no screen or a defective screen in strainer would allow foreign particles to foul liquid double check valve. CO₂ gas could then back flow into water system and create a health hazard in the water system

Refer to manual provided with carbonator assembly for service and maintenance instructions.

ADJUSTING PRIMARY CO₂ REGULATORS

(see Figure 7).

System Connected to Bulk CO₂ Supply

Adjust primary CO₂ regulator on bulk CO₂ supply tank to 105-PSI (7.24 Bars)

System Connected to Two-Fifty Pound CO₂ Cylinders

Adjust two primary CO₂ regulators to 105-PSI (7.24 Bars)

ADJUSTING SECONDARY CO₂ REGULATORS

Sugar-Base Syrup Tanks CO₂ Regulator

Adjust sugar-base syrup tanks CO₂ regulator with 100-PSI (6.9 Bars) gauge on secondary CO₂ regulator assembly to 60-PSI (4.14 Bars).

Diet-Syrup Tank CO₂ Regulator.

Adjust diet-syrup tank CO₂ regulator with 30-PSI (2.07 Bars) gauge on secondary CO₂ regulator assembly to 12-PSI (.83 Bars).

CHECKING PLAIN WATER SYSTEM SURGE TANK AIR, CO₂ OR NITROGEN GAS PRESSURE (see applicable Figure 3, 4, 5, or 6).

NOTE: The plain water surge tank must be completely drained before proceeding to check and if necessary, pressurize the tank with the proper amount of “commercially dry air, CO₂, or nitrogen gas pressure. Proceed as follows:

1. Unplug carbonator(s) and if applicable, the optional Water Pressure Booster system power cords from electrical outlets
2. Close Beverage Control Panel Assembly main water inlet supply line shutoff valve.
3. Close plain water outlet shutoff valve Post-Mix Dispenser plain water line is connected to.
4. Disconnect Post-Mix Dispenser plain water line from shutoff valve.
5. Place bucket under shutoff valve. Open shutoff valve and allow water to be purged from surge tank. **DO NOT CLOSE VALVE AT THIS TIME.**
6. Note: service valve on bottom of the water system surge tank. The surge tank must be pressurized to 12 ± 2-PSI (.83 ± .14 Bars) with commercially dry air, CO₂, or nitrogen gas pressure. Check and make sure surge tank is properly pressurized.
7. Close Post-Mix Dispenser plain water outlet shutoff valve.
8. Open Beverage Control Panel Assembly main water inlet supply line shutoff valve.
9. Plug the carbonator(s) and if applicable, the optional Water Pressure Booster system power cords into electrical outlet.
10. Place bucket under Post-Mix Dispenser plain water outlet shutoff valve. Open shutoff valve until a good stream of water flows from valve, the close valve.
11. Reconnect Post-Mix Dispenser water line to shutoff valve.

SERVICING OPTIONAL WATER PRESSURE BOOSTER SYSTEM

(see applicable Figure 3, 4, 5, or 6)

Servicing Water Pump Water Inlet Strainer Screen

1. Unplug carbonator(s) and the Water Pressure Booster system power cords from electrical outlets.

2. Close Beverage Control Panel Assembly water inlet supply line shutoff valve.
3. Loosen screen retainer, then pull screen retainer and strainer screen from water pump. (see Figure 12).
4. Pull strainer screen from screen retainer. Clean any sediment from screen retainer and pump screen retainer port.

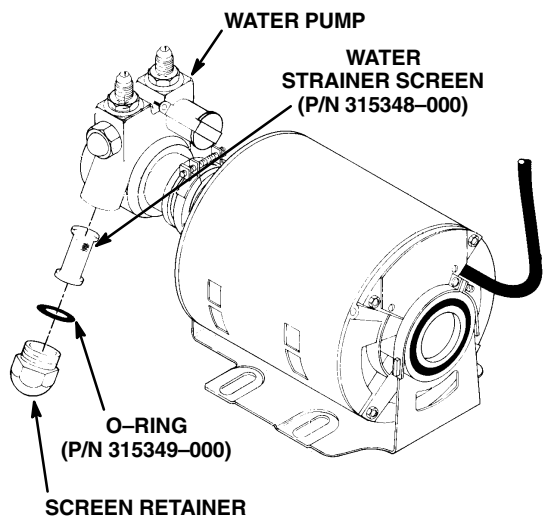

FIGURE 12. WATER STRAINER SCREEN

5. Inspect strainer screen for holes, restrictions, corrosion, and other damage. Discard damaged strainer screen.
6. Check O-Ring on screen retainer. Replace worn or damaged O-Ring (P/N 315349-000).

NOTE: A strainer screen should always be used, otherwise particles could foul liquid check valve.

7. Install good or new strainer screen (P/N 315348-000) in screen retainer, then screw retainer into water pump and tighten securely.
8. Service liquid check valve (refer to next paragraph, Servicing Liquid Check Valve).

Servicing Liquid Check Valve

1. Service water pump water strainer screen as instructed in previous paragraph, Servicing Water In let Strainer Screen; before servicing liquid check valve.
2. Disconnect pressure switch (see Figure 13) from liquid check valve assembly outlet, then remove check valve from water pump outlet. Retain white tapered gasket inside inlet (female) end of check valve.

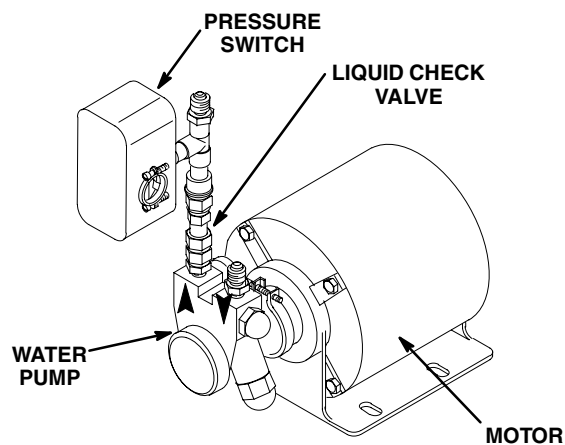
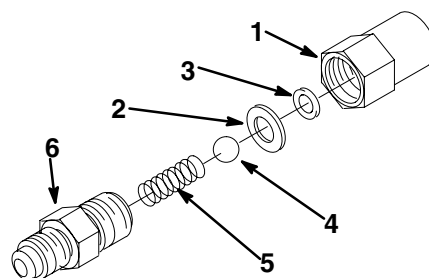

FIGURE 13. WATER PUMP AND MOTOR



Index No.	Part No.	Name
1	317963	Housing
2	312415	Flat Washer, Stainless Steel
3	*312418	Ba;; Seat (quad ring)
4	312419	Ball
5	312196	Spring
6	317965	Retainer

*Install new ball seat at each servicing.

FIGURE 14. LIQUID CHECK VALVE ASSEMBLY

3. Disassemble each check valve as shown in Figure 14
4. Wipe each part with clean lint-free cloth. Inspect each part, especially ball for burrs, nicks, corrosion, deterioration, and other damage. Discard ball seat and any damaged or suspicious parts and replace with new parts when reassembled.
5. Reassemble check valve as shown in Figure 14. ALWAYS INSTALL NEW BALL SEAT (QUADDING) P/N 312418-000.
6. Make sure white tapered gasket is in place inside female end of check valve assembly, then install check valve assembly on fitting in water pump outlet port.
7. Connect pressure switch to check valve assembly outlet.

8. Open Beverage Control Panel Assembly water inlet supply line shutoff valve.
9. Plug carbonator(s) and the Water Pressure Booster system power cords into electrical outlets.

Checking Water Tank Air, CO₂, or Nitrogen Gas Pressure

NOTE: The Water Pressure Booster system water tank must be completely drained before proceeding to check and if necessary, pressurize the tank with the proper amount of commercially dry air, CO₂, or nitrogen gas pressure. Proceed as follows:

1. Unplug carbonator(s) and Water Pressure Booster system power cords from electrical outlets.
2. Close Beverage Control Panel Assembly water inlet supply line shutoff valve.
3. Close plain water outlet shutoff valve Post-Mix Dispenser plain water line is connected to.
4. Disconnect Post-Mix Dispenser plain water line from shutoff valve.
5. Place bucket under shutoff valve. Open shutoff valve and allow water to be purged from Water Pressure Booster System water tank, then close valve.
6. Note service valve (see applicable Figure 3, 4, 5, or 6) on bottom of the Water Pressure Booster system water tank. The water tank must be pressurized to 40 ± 5-PSI (2.76 ± .34 Bars) with commercially dry air, CO, or nitrogen gas pressure. Check and make sure water tank is properly pressurized.
7. Open Beverage Control Panel Assembly water inlet supply line shutoff valve.
8. Place bucket under Post-Mix Dispenser shutoff valve. Open valve and allow water to flow until a good stream of water flows from valve, then close valve.
9. Reconnect Post-Mix Dispenser plain water line to shutoff valve.
10. Plug both carbonators and Water Pressure Booster System power cords into electrical outlets.

Adjusting Pressure Switch “CUT OUT” (pump stops) and “CUT IN” (pump starts).

NOTE: The Water Pressure Booster system water tank and the water system surge tank must be completely drained and make sure they are properly pressurized with commercially dry air, CO₂, or nitrogen gas pressure before checking the water pump “CUT-IN” (pump starts) and “CUT-OUT” (pump stops). Proceed as follows:

1. Unplug carbonator(s) and Water Pressure Booster system power cords from electrical outlets.
2. Close Beverage Control Panel Assembly water inlet supply line shutoff valve.
3. Close water manifold plain water shutoff valve Post-Mix Dispenser plain water line is connected to. Disconnect water line from shutoff valve.
4. Place bucket under shutoff valve. Open shutoff valve and allow water to be purged from water system surge tank and Water Pressure Booster System water tank. DO NOT CLOSE SHUTOFF VALVE AT THIS TIME.
5. Note service valve on bottom of Water Pressure Booster system water tank and water system surge tank. The Water Pressure Booster system water tank must be checked to make sure it is pressurized to 40 ± 5-PSI (2.76 ± .034 Bars) and the water system surge tank is pressurized to 12 ± 2-PSI (.83 ± .14 Bars) with commercially dry air, CO₂, or nitrogen gas pressure.
6. Close Post-Mix Dispenser water outlet shutoff valve, then open Beverage Control Panel Assembly plain water inlet supply line shutoff valve.
7. Place bucket under Post-Mix Dispenser water outlet shutoff valve. Open shutoff valve and allow water to flow until water surge tank and Water Pressure Booster System water tank are filled and a good stream of water flows from shutoff valve, then close valve.

CAUTION: To avoid damage, do not exceed the maximum allowable system pressure of 85 ± 5-PSI (5.86 ± .35 Bars).

 **WARNING: Adjustment nuts are located close to the high voltage terminals on the pressure switch. To prevent possible electrical shock, use an insulated 3/8 nut-driver to make adjustments. Only qualified personnel should perform adjustments on pressure switch.**

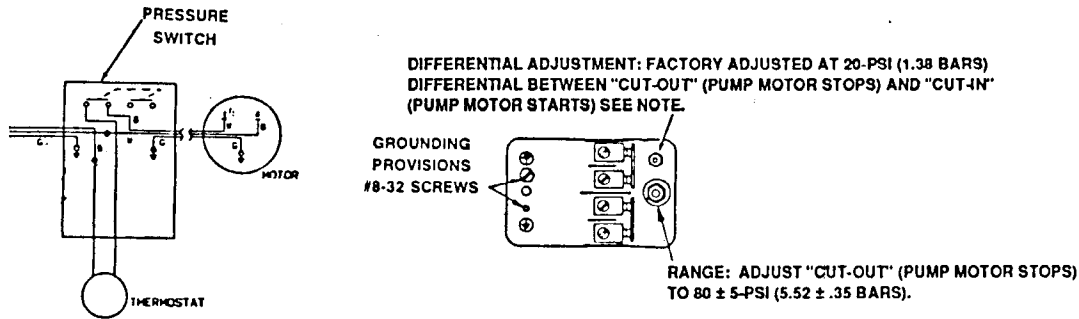

Note: The DIFFERENTIAL adjustment (20-psi) between “CUT-IN” (water pump starts) and “CUT-OUT” (water pump stops) has been adjusted at the factory and should require no further adjustment. Should differential adjustment become necessary, turn DIFFERENTIAL ADJUSTMENT nut clockwise to increase differential or turn nut counterclockwise to decrease differential.

FIGURE 15. PRESSURE SWITCH ADJUSTMENT

8. Using 5/16 nutdriver, remove nut securing pressure switch cover, then remove cover.

Note: Water pressure gauge to be observed when checking “CUT-OUT” (water pump stops) is located just above the water filters. Observing the water pressure gauge, “CUT-OUT” (water pump stops) should occur at 85 ± 5-PSI (5.86 ± .35 Bars).

9. Plug Water Pressure Booster System power cord into electrical outlet.
10. Open Post-Mix Dispenser water outlet shutoff valve and discharge water into bucket until pump “CUT-IN” (pump starts) occurs, then close valve. Pump “CUT-OUT” should have occurred at 85 ± 5-PSI (5.86 ± .35 Bars). If pump “CUT-OUT” was not correct, refer to Figure 15 and turn “CUT-OUT” adjustment nut to the right (clockwise) for higher pressure or to the left (counterclockwise) for lower pressure.
11. Repeat step 10) preceding and adjust until proper pump “CUT-OUT” occurs.
12. Install pressure switch cover and secure with nut.
13. Re-connect Post-Mix Dispenser plain water line to Water manifold water shutoff valve.
14. Plug carbonator(s) power cord(s) into electrical outlet.

SERVICING OPTIONAL AIR COMPRESSOR ASSEMBLY AND AIR SYSTEM MAINTENANCE

Air Compressor Maintenance.

Air compressor assembly air filter must be cleaned or replaced with replacement air filter (P/N 111421-000) every 30 to 60 days or more often, depending upon environmental conditions.

Purging Air Reservoir Tank (Weekly)

IMPORTANT: To prevent water (condensation) from entering system, water must be purged from air reservoir tank once a week.

1. Hold appropriate container under bleeder valve on air reservoir tank (see Figure 7).
2. Open valve to allow water (condensation) to be purged from reservoir tank and until only air comes out of valve, then close valve.

CLEANING OPTIONAL SYRUP LINES STRAINERS (SEE FIGURE 15).

NOTE: Use ONLY LUKEWARM WATER. Hot water destroys the chlorine power of the sanitizer and cold water does not allow the sanitizer to dissolve. Lukewarm is warm but not HOT, approximately body temperature.

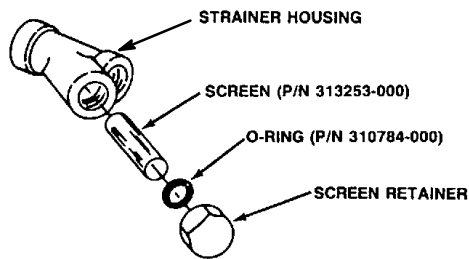

FIGURE 16. SYRUP LINE STRAINER

1. Using chlor-tergent (Oakite Products, Inc.) or equivalent sanitizer and LUKEWARM water, mix 2–1/2 gallons (9.46 liters) of sanitizing solution in a bucket.
2. Disconnect syrup out quick disconnects, containing the syrup strainers, from all syrup tanks.
3. Activate all dispensing valves on Dispensers to relieve pressure from all syrup systems.
4. Loosen syrup strainer screen (see Figure 3–5) retainer, then pull syrup strainer and screen from syrup strainer housing.
5. Pull screen from screen retainer. Inspect screen for holes, restrictions, corrosion, and any other damage. Discard damaged screen and replace with a new one.
6. Place quick disconnect and syrup strainer housing in bucket containing sanitizing solution. Thoroughly wash quick disconnect and syrup strainer housing, screen retainer, and screen in sanitizing solution.
7. Thoroughly rinse quick disconnect and syrup strainer housing, screen retainer and screen with potable water.
8. Install screen in screen retainer, then screw screen retainer into water strainer housing. Tighten retainer only finger tight.
9. Repeat steps 4) through 8) to clean and sanitize remaining syrup strainers.
10. Sanitize all syrup systems as instructed.

11. Connect syrup out quick disconnects to all syrup tanks.

WATER FILTERS REPLACEMENT

Refer to Water Filtration System manual for water filters replacement instructions.

SANITIZING SYRUP SYSTEMS

The syrup systems should be sanitized every 90–days using Chlor-Tergent (Oakite Products, Inc.) or equivalent sanitizer. Refer to manual provided with the Post-Mix Dispenser for sanitizing instructions.

REPLENISHING CO₂ SUPPLY

NOTE: When indicator on CO₂ cylinder regulator assembly 1800–PSI (124.1 Bars) gauge is in shaded (“Change CO₂ Cylinder”) portion of dial, CO₂ cylinder is almost empty and should be changed.

1. Fully close (clockwise) CO₂ cylinder valve.
2. Slowly loosen CO₂ regulator assembly coupling nut allowing CO₂ pressure to escape, then remove regulator assembly from empty CO₂ cylinder.
3. Unfasten safety chain and remove empty CO₂ cylinder.

⚠ WARNING: To avoid personal injury and/or property damage, always secure CO₂ cylinder with safety chain to prevent it from falling over. Should the valve become accidentally damaged or broken off, CO₂ cylinder can cause serious personal injury.

4. Position CO₂ cylinder and secure with safety chain.
5. Make sure gasket is in place inside CO₂ regulator coupling nut, then install regulator on CO₂ cylinder.
6. Open (counterclockwise) CO₂ cylinder valve slightly to allow lines to slowly fill with gas, then open valve fully to back-seat valve. (Back-seating valve prevents leakage around valve shaft).
7. Check CO₂ connections for leaks. Tighten loose connections.

REPLENISHING SYRUP SUPPLY

⚠ WARNING: To avoid personal injury or property damage, do not attempt to remove syrup tank cover until CO₂ pressure has been released from tank.

1. Remove CO₂ disconnect and syrup disconnect from empty syrup tank, then remove tank.
2. Place full syrup tank in position, then connect CO₂ disconnect and syrup disconnect to full syrup tank.

SYRUP FLAVOR CHANGE

Sanitize applicable syrup system as instructed, then install full tank of new flavor syrup.

TROUBLESHOOTING

IMPORTANT: Only qualified personnel should service internal components or electrical wiring.



WARNING: If repairs are to be made to carbonated water system, disconnect electrical power to Cooling Unit, shut off plain water and CO₂ supplies, and relieve the carbonated water system pressure before proceeding. If repairs are to be made to syrup system, remove quick disconnects from applicable syrup tank, then relieve the system pressure before proceeding. If repairs are to be made to CO₂ system, stop dispensing, shut off CO₂ supply, then relieve the system pressure before proceeding.
If repairs are to be made to an existing Remote Condensing unit, disconnect the power to the condensing unit before proceeding

TROUBLESHOOTING OPTIONAL WATER PRESSURE BOOSTER SYSTEM

Trouble	Probable Cause	Remedy
WATER PUMP NOT OPERATING	<ul style="list-style-type: none"> A. Power cord unplugged from electrical outlet. B. Electrical circuit fuse blown or circuit breaker tripped. C. Water pump motor inoperative D. Water pump pressure switch inoperative. E. Thermal overload switch inoperative. F. Plain water inlet pressure above 60-PSI (4.14 Bars). 	<ul style="list-style-type: none"> A. Plug power cord into electrical outlet. B. Replace fuse or reset circuit breaker. C. Have Service Technician replace inoperative moto D. Have Service Technician replace inoperative pressure switch. E. Have Service Technician replace inoperative thermal overload switch. F. Have Service Technician reset "CUT IN" pressure on pressure switch to 10-PSI (.68 Bars) above water inlet pressure.
WATER PUMP "SHORTCYCLES"	<ul style="list-style-type: none"> A. Water tank is overcharged with air, CO₂ or nitrogen gas. B. Check to see if check valve on water pump outlet is leaking water C. Water tank shutoff valve is closed D. Water pump pressure switch is not correctly adjusted. 	<ul style="list-style-type: none"> A. Evacuate all water from Beverage Support System. Adjust pressure to 40 ± 5-PSI (2.76 ± .34 Bars), then reactivate system. B. Disassemble and clean check valve. If valve is damaged, replace. C. Open water tank shutoff valve D. Have Service Technician readjust the pump pressure switch.
WATER PUMP "LONG CYCLES"	<ul style="list-style-type: none"> A. Water tank is undercharged with air, CO₂, or nitrogen gas. B. Water tank gas bladder is leaking. 	<ul style="list-style-type: none"> A. Evacuate all water from Beverage Support System. Adjust gas pressure to 40 ± 5 PSI, (2.76 ± .34 Bars) then reactivate system. B. Replace water tank, pressurize gas pressure to 40 ± 5-PSI (2.76 ± .34 Bars), then reactivate.

Trouble	Probable Cause	Remedy
WATER PUMP "LONG CYCLES" (CON'T)	C. Water pump pressure switch is not correctly adjusted.	C. Verify pressure switch "CUT-OUT" pressure is adjusted at 85 ± 5 PSI ($5.86 \pm .35$ Bars) or "CUT-IN" pressure is adjusted at 60 ± 5 PSI ($4.14 \pm .35$ Bars). Have Service Technician readjust pressure switch.
	D. Water pre-filter is plugged (this condition will be accompanied by a change in pitch of the water pump when operating.)	D. If water inlet pressure gauge reads below 5-PSI (.34 Bars) while water pump is operating,replace water pre-filter.
	E. Water supply is shut off to Beverage Control Panel (this condition will be accompanied by a change in pitch of the water pump when operating).	E. Verify plain water inlet shutoff valve is in "OPEN" position. Verify all other water shutoff valves on Beverage Control Panel are in "OPEN" positions.
	F. Water pump failure.	F. Have Service Technician replace water pump. Verify water is being supplied to the pump (starving water pump of water is primary reason for pump failure).
	G. Water filter activation valve is in "OPEN" position.	G. Place water filter activation valve in "CLOSED" position.
	H. Leak in plain water lines leaving Beverage Control Panel Assembly.	H. Check for water leak in plain water lines leading to equipment connected to Beverage Control Panel Assembly.
	A. Water inlet shutoff valve is in "CLOSED" position.	A. Place water inlet shutoff valve in "OPEN" position.
	B. Water pre-filter is clogged.	B. Replace water pre-filter.
WATER INLET PRESSURE GAUGE READS TOO LOW	C. Water pressure regulator is incorrectly adjusted.	C. Readjust water pressure regulator to 75 ± 5 PSI. ($5.17 \pm .34$ Bars)
	D. Water pressure regulator strainer is clogged.	D. Remove and clean or replace the water strainer screen.
	E. Water pressure regulator inoperative.	E. Replace water pressure regulator and adjust to 75 ± 5 PSI. ($5.17 \pm .34$ Bars)
	A. Water pressure regulator is incorrectly adjusted.	A. Readjust water pressure regulator to 75 ± 5 PSI. ($5.17 \pm .34$ Bars)
	B. Water pressure regulator inoperative.	B. Replace water pressure regulator and adjust to 75 ± 5 PSI. ($5.17 \pm .34$ Bars)
WATER INLET PRESSURE GAUGE READS TOO HIGH	A. Power cord unplugged from electrical outlet.	A. Plug air compressor power cord into electrical outlet.
	B. Power cord power switch in "OFF" position.	B. Place power switch in "ON" position.
	C. Electrical circuit fuse blown or circuit breaker tripped.	C. Replace fuse or reset circuit breaker.
	D. Air compressor pressure switch is inoperative.	D. Have Service Technician check and/or replace pressure switch.
AIR COMPRESSOR DOES NOT OPERATE		

Trouble	Probable Cause	Remedy
AIR COMPRESSOR DOES NOT OPERATE (CON'T)	E. Air/CO ₂ changeover valve on CO ₂ panel set to CO ₂ position.	E. Select desired valve position.
	F. Air compressor is inoperative.	F. Replace air compressor.
AIR COMPRESSOR 'SHORT CYCLES'	A. Air compressor pressure switch is not correctly adjusted.	A. Have Service Technician adjust pressure switch.
	B. Air tank contains water (condensation).	B. Drain water (condensation) from air tank by opening condensation drain tube valve. Close valve after draining tank. TO PREVENT WATER (CONDENSATION) FROM ENTERING SYSTEM, WATER MUST BE PURGED FROM AIR TANK ONCE A WEEK.
DISPENSED DRINKS HAVE 'OFF' TASTE	A. Air tank contains excessive water (condensation).	A. Drain water (condensation) from air tank, then sanitize syrup systems and replace contaminated syrup supplies.
AIR COMPRESSOR'LONG CYCLES'	A. Condensation drain tube valve on air tank is in "OPEN" position.	A. Place condensation drain valve in "CLOSED" position.
	B. Pressure relief valve on air tank lid is open	B. Close air tank lid relief valve.
	C. Air compressor air filter is clogged.	C. Replace air compressor air filter.
	D. Air tank lid not properly installed.	D. Properly install lid on air tank.
	E. Leak in air system lines and/or regulators.	E. Check for leak in air line from air compressor to air tank. Check line from air tank to air/CO change over valve. Check regulator and lines to syrup tanks. Check line to shake machine.
	F. Air compressor inoperative	F. Replace air compressor.
WATER INLET PRESSURE GAUGE READS TOO LOW	A. Water inlet valve in "CLOSED" position.	A. Place water inlet shutoff valve in "OPEN" position.
	B. Water pre-filter is clogged.	B. Replace water pre-filter.
	C. Water pressure regulator is incorrectly adjusted.	C. Readjust water pressure regulator to 75 ± 5 PSI (5.17 ± .34 Bars).
	D. Water pressure regulator strainer is clogged. Water pressure regulator strainer is clogged.	D. Clean or replace water strainer filter after closing main water shutoff valve.
	E. Water pressure regulator inoperative.	E. Call Service Technician.
WATER INLET PRESSURE GAUGE READS TOO HIGH	A. Water pressure regulator is incorrectly adjusted.	A. Readjust water pressure regulator to 75-PSI (5.17 Bars)
	B. Water pressure regulator inoperative.	B. Call Service Technician.

NOTE: Refer to manual provided with carbonator for troubleshooting information.

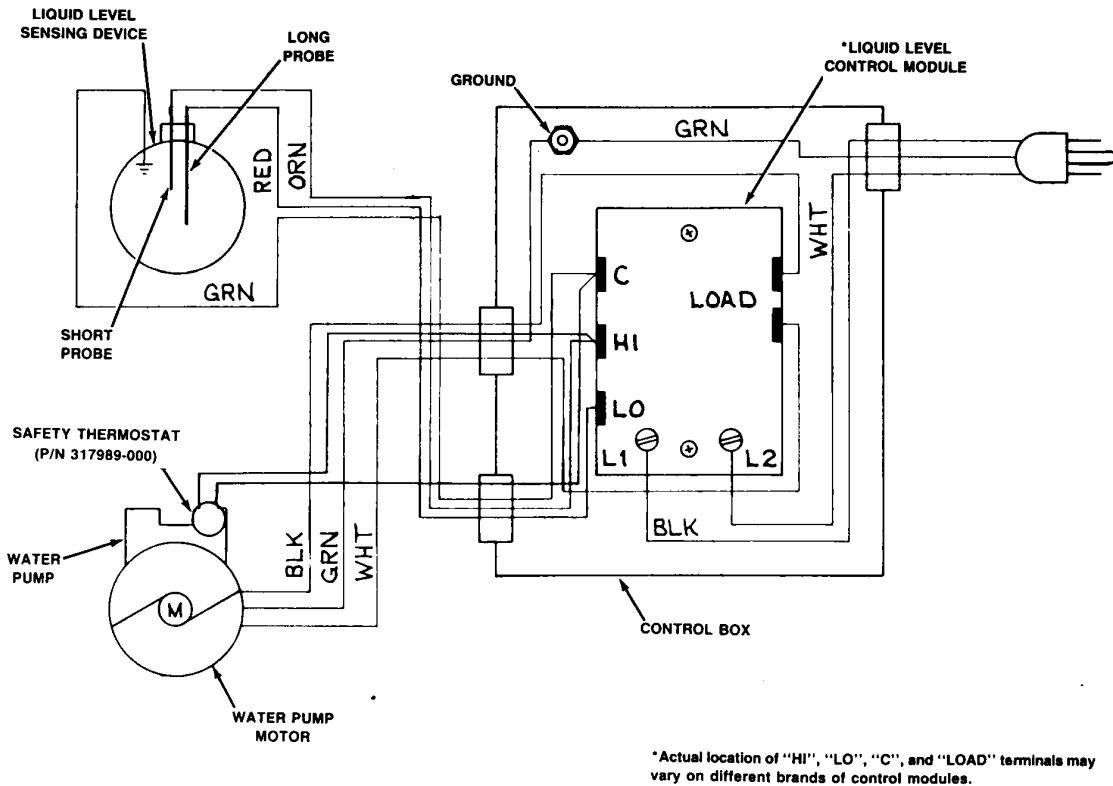

FIGURE 1. WIRING DIAGRAM (CARBONATOR)

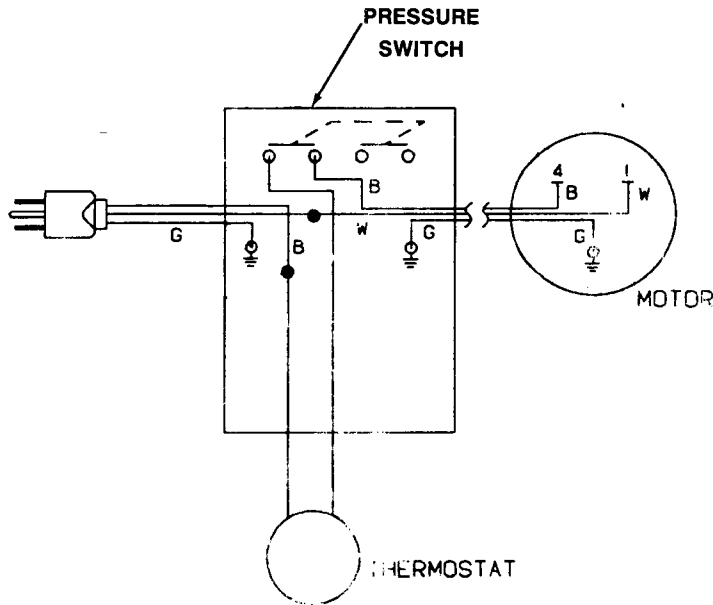
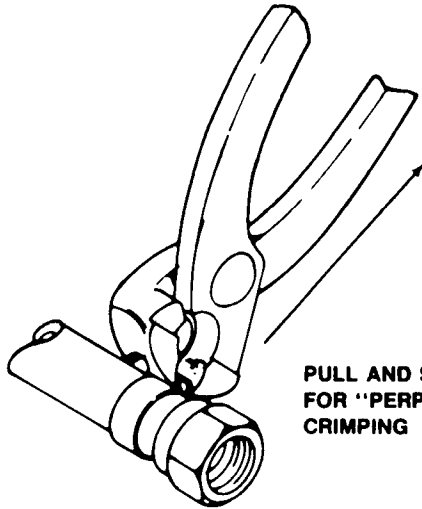
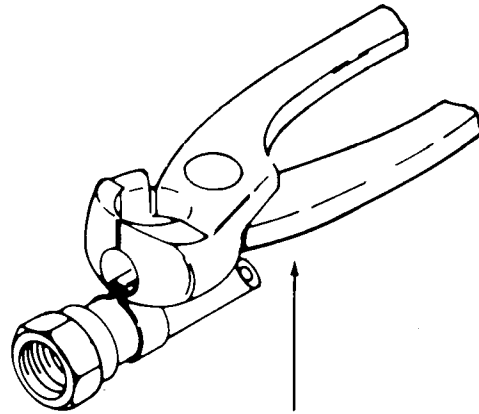

FIGURE 2. WIRING DIAGRAM (OPTIONAL WATER PRESSURE BOOSTER SYSTEM)

**INSTRUCTIONS
for
CRIMPING TUBE CLAMPS**



**PULL AND SQUEEZE Pincer
FOR "PERPENDICULAR"
CRIMPING**



**LIFT AND SQUEEZE Pincer
FOR "PARALLEL" OR
"SIDE SADDLE" CRIMPING**

**SLIDE CLAMPS ON
TUBING BEFORE INSTALLING
TUBING ON FITTING**

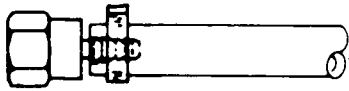

**POSITION CLAMP BEHIND
FIRST BARB FITTING
FOR CRIMPING**

DO

**PROPER
CRIMPING**



DON'T

**IMPROPER
CRIMPING**



ONE-SIDED



TWISTED



**OVER-
CRIMPED**

FIGURE 3. INSTRUCTIONS FOR CRIMPING TUBE CLAMPS

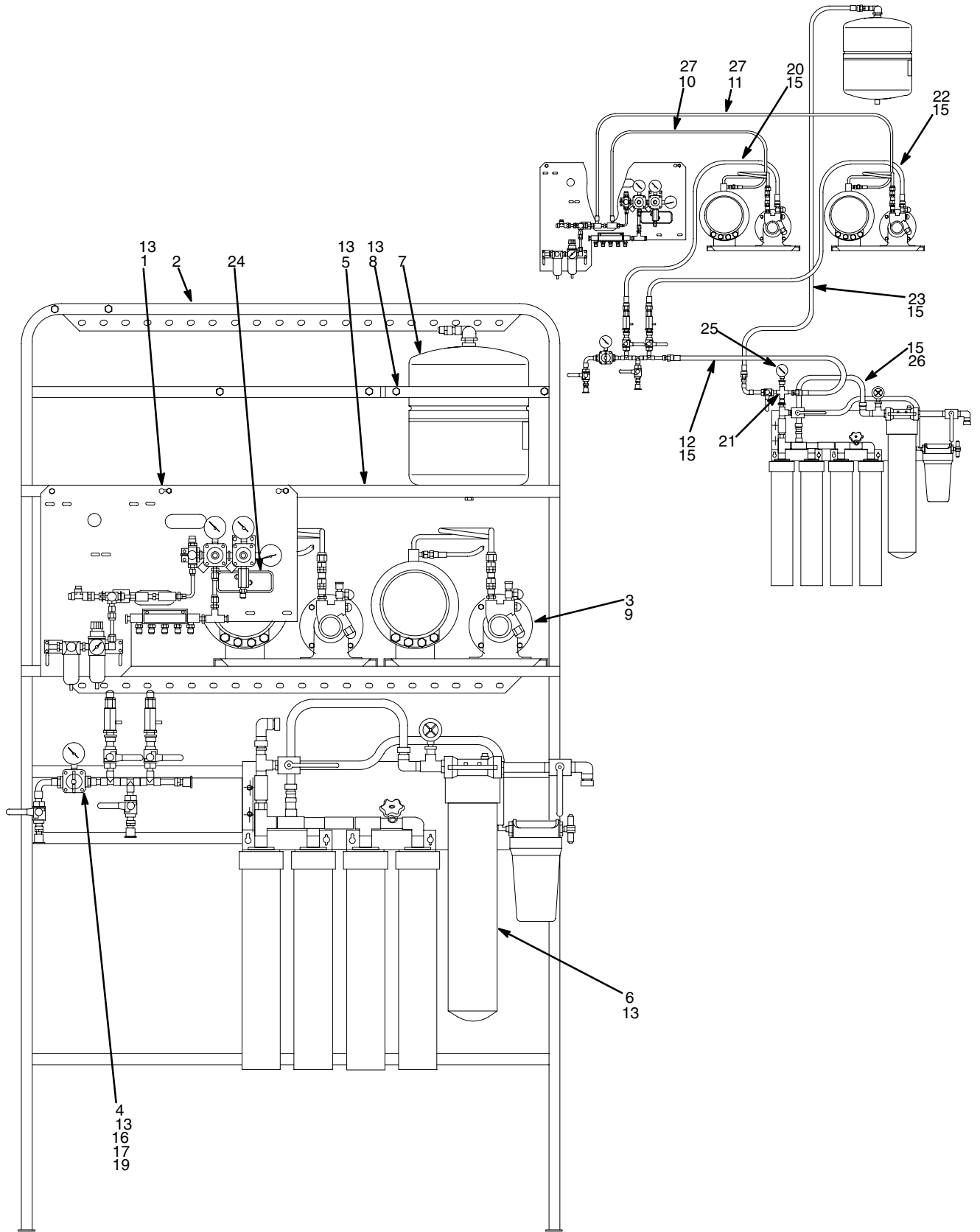

FIGURE 17. BEVERAGE CONTROL PANEL ASS'Y

BEVERAGE CONTROL PANEL ASS'Y

Item No.	Part No.	Name
	1416	Beverage Control Panel Ass'y One Carbonator, Domestic
	0516	Beverage Control Panel Ass'y Two Carbonator, Domestic
	1548	Beverage Control Panel Ass'y One Carbonator, Export
	0187	Beverage Control Panel Ass'y Two Carbonator, Export
1	0483	CO ₂ Regulator Ass'y (see Figure 5-2)
2	300911	Frame, Upper
3	416424	Carbonator Ass'y, Domestic (see Figure 5-9)
	496424	Carbonator Ass'y, Export (see Figure 5-9)
4	300914	Manifold Ass'y, Water (see figure 5-10)
5	0657	Platform, Surge Tank
6	0504	Filter System Ass'y Everpure
	0928	Filter System Ass'y Cuno
7	300984	Surge Tank, 100 PSI Domestic
8	300893	Strap, Surge Tank Domestic
9	*0875	Self Drilling Screw, Hex Washer HD, No. 10-16 by 1 1/4" Long
10	0505	Tube Ass'y, .265 I.D. By 30" Long, From CO ₂ Regulator Ass'y to Center Island Carbonator Ass'y
11	315499	Cap, 1-Carbonator
	0506	Tube Ass'y, .265 I.D. by 44" Long, from CO ₂ Regulator Ass'y to Drive-Thru Carbonator Ass'y 2-Carbonator
12	0507	Tube Ass'y, .375 I.D. By 21" Long, from Water Manifold Ass'y to Water Manifold (2-Carbonator)
13	*320940	Self Drilling Screw Hex Washer HD, No. 10-16 By 5/8" Long

Item No.	Part No.	Name
14	*1300	Washer, .229 I.D. By .049CS
15	311304	Tapered Gasket Black
16	318556	Hanger
17	189429	Hex Nut Keps, 1/4-20 Domestic
	*321811	Hex Nut, Keps, No. 10-32 Export
18	165294	Hex Bolt, 1/4-20 By 1" Long (1-Carbonator)
19	200469-029	Machine Screw, Phil Pan HD No. 1/4-20 By 1-3/8 Long (Domestic, 2-Carbonator)
	183040	Machine Screw, Fil Pan HD NO. 10-32 By 7/8" Long, (Export, 2-Carbonator)
20	0508	Tube Ass'y, .375 I.D. By 36" Long From Water Manifold Ass'y to Center Island Carbonator Ass'y
21	0193	Water Manifold Ass'y (see Figure 5-11)
22	0705	Tube Ass'y, .375 I.D. By 49" Long, From Water Manifold Ass'y to Drive-Thru Carbonator Ass'y 2-Carbonator
23	300912	Tube Ass'y, .375 I.D. By 56" Long, Surge Tank to Water Manifold Ass'y Domestic
24	960194	Rubber Channel
25	0143	Gauge, 160 PSI
26	0846	Tube Ass'y, .375 I.D. By 9" Long, Water Filter Ass'y Everpure
	176272-318	Tube Ass'y, .375 I.D. By 18" Long, Water Filter Ass'y, Cuno
27	178025-100	Tapered Gasket White
28	309812	Tube, Water Inlet, Stainless Steel (not Shown)

*Zinc Plated Steel Unless Otherwise Indicated.

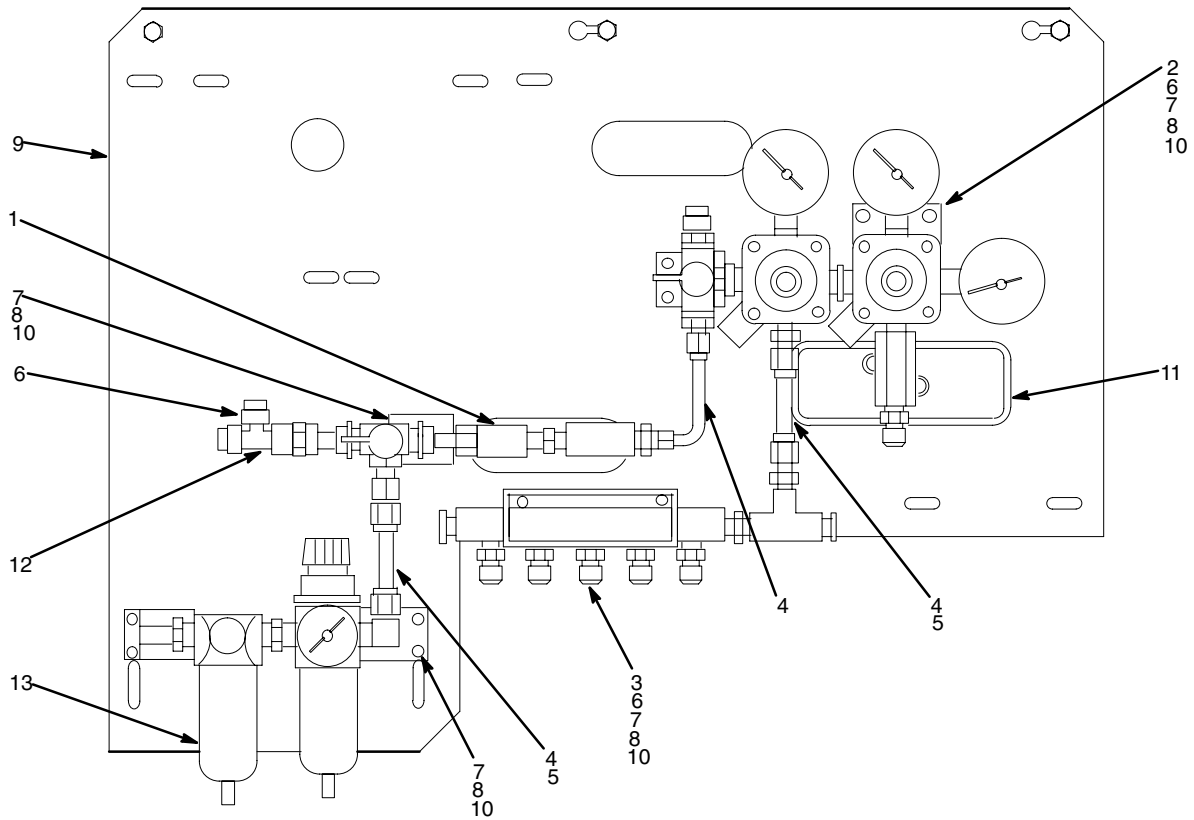
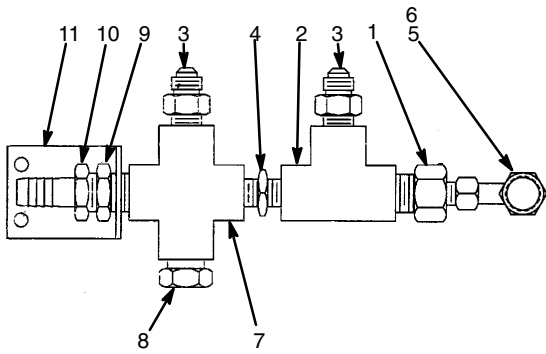

FIGURE 18. CO₂ REGULATOR ASS'Y (P/N 0483)

Item No.	Part No.	Name
	0483	CO ₂ Regulator Ass'y
1	0137	Manifold Ass'y Carbonator (see Figure 5-3)
2	0138	Regulator Ass'y syrup (see Figure 5-5)
3	0145	Manifold and Bracket Ass'y CO ₂ (see Figure 5-8)
4	178025-100	Tapered Gasket, White
5	311732	Connector, Swivel, 7/16-20
6	315499	Cap, 7/16
7	398022-400	Machine Screw, SL RD HD Stainless Steel, No. 10-24 By 5/8" Long
8	*398024-603	Hex Nut, NO 10-24
9	1375	Panel Mounting
10	331400	Washer .203 I.D. By .024
11	960194	Edging
12	1665	Carbonator manifold ass'y
13	1668	Air Filter Ass'y

*Zinc Plated Steel Unless Otherwise Indicated.



Item No.	Part No.	Name
	0137	Manifold Ass'y Carbonstor
1	320640	Fitting 1/4 NPT By 7/16-20
2	183060	Fitting, Tee 1/4 NPT
3	183301-100	Check Valve Ass'y (see figure 5-4)
4	183047	Fitting 1/4 NPT
5	176065	Fitting, Swivel Elbow, 7/16-20
6	178025-100	Tapered Gasket, White
7	183046	Fitting, Cross, 1/4 NPT
8	130066	Fitting, Plug, 1/4-NPT
9	77075001	Fitting, 7/16-20 By 1/4-NPT
10	77080801	Fitting, 3/8-Barb by 7/16-20
11	0656	Bracket, Regulator

FIGURE 19. CARBONATOR MANIFOLD ASS'Y (P/N 0137)

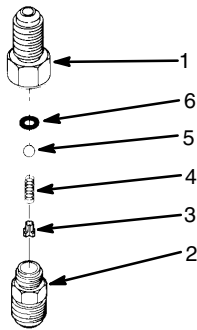

Item No.	Part No.	Name
	183301-100	Check Valve Ass'y
1	183300-001	Manifold, 1 Port
2	183295-100	Body
3	183298	Retainer, Spring
4	183296	Ball
5	183297	Spring
6	183294	Quad Ring, .145 I.D. By .070CS

FIGURE 20. CO₂ CHECK VALVE ASS'Y (P/N 183301-001)

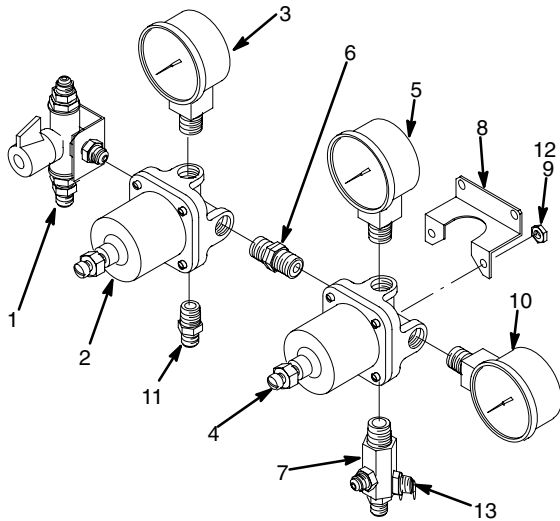

Item No.	Part No.	Name
	0138	Regulator Ass'y Syrup
1	311904	Change Over Valve
2	183412	Regulator Ass'y, 100-PSI (see figure 5-6)
3	183286	Gauge, 100 PSI
4	183446	Regulator Ass'y, 30-PSI (see Figure 5-6)
5	183288	Gauge, 30-PSI
6	183047	Fitting, 1/4 NPT
7	183302-100	Check Valve and Manifold Ass'y (see Figure 5-7)
8	183317	Bracket, Regulator
9	321811	Hex Nut, Keps, NO 10-32
10	183285	Gaugge, 160-PSI
11	183301-100	Check Valve Ass'y (see Figure 5-4)
12	183040	Machine Screw, SL Pan HD No. 10-32 By 2-1/4" Long
13	315499	Cap

FIGURE 21. SYRUP REGULATOR ASS'Y (P/N 0138)

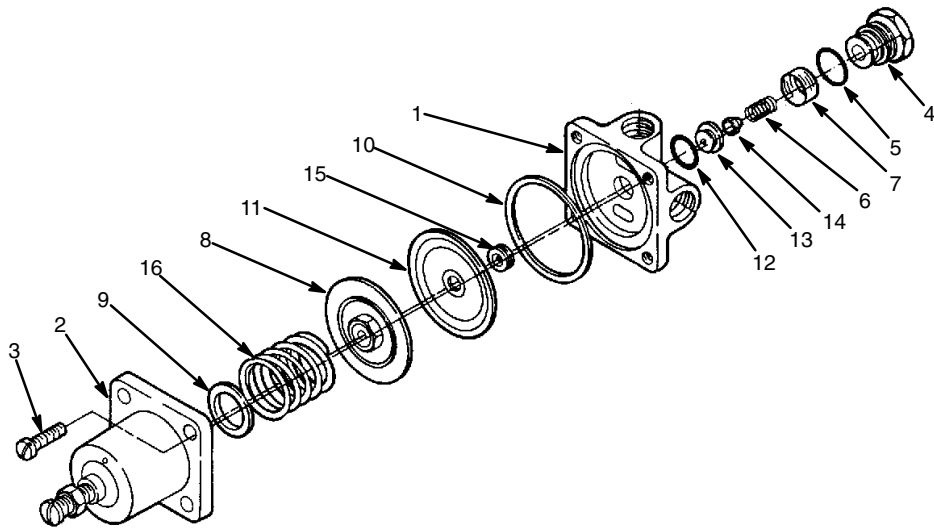
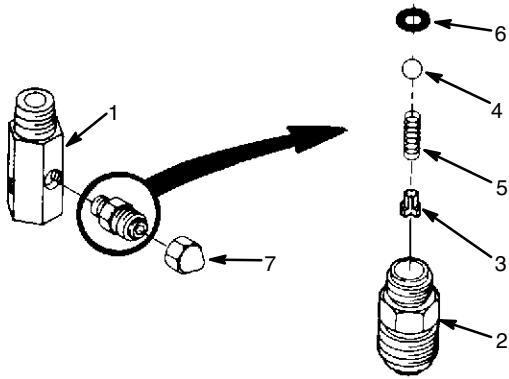

FIGURE 22. CO₂ REGULATOR ASS'Y

Item No.	Part No.	Name
	183412	Regulator Ass'y, 100 PSI
	183446	Regulator Ass'y, 30 PSI
	183586	Regulator Ass'y 160 PSI
1	183001-007	Body (30 PSI and 100 PSI)
	183265	Body (160 PSI)
2	183233	Cover Kit (Includes, Non-Removable Adjusting Screw)
3	*120081	Machine Screw, Phil Fil HD NO. 10-32 By 1/2" Long
	183040	Machine Screw, Phil Fil HD, No. 10-32 By 7/8" Long
4	183009-007	Retainer Seat
5	183008	O-Ring, .489 I.D. By .070 CS
6	183006	Spring, Poppet
7	183007-000	Filter Sleeve
8	130147	Diaphragm Assembly

Item No.	Part No.	Name
9	183021	Spring Retainer
10	183010	Gasket, Baffle
11	183011-007	Baffle
12	183003	Gasket, Seat
13	130168	Reducing Valve Seat (30 PSI and 100 PSI)
	183002	Reducing Valve Seat (160 PSI)
14	130170	Poppet Ass'y (30 PSI and 100 PSI)
	183063	Poppet Ass'y (160 PSI)
15	130167	Guide (30 PSI and 100 PSI)
	183012	Guide (160 PSI)
16	183020	Adjusting Spring, Sliver, 100 PSI
	183064	Adjusting Spring, Bronze, 160 PSI
	315424	Adjusting Spring, Blue, 30 PSI

*Zinc Plated Steel Unless Otherwise Indicated.



Item No.	Part No.	Name
	183302-100	Check Valve Ass'y
1	183300-003	Manifold, 3 Port
2	183295-100	Body
3	183298	Retainer, Spring
4	183296	Ball
5	183297	Spring
6	183294	Quad Ring, .145 I.D. By .070 CS
7	315499	Cap

FIGURE 23. CHECK VALVE AND MANIFOLD ASS'Y (P/N 183302-100)

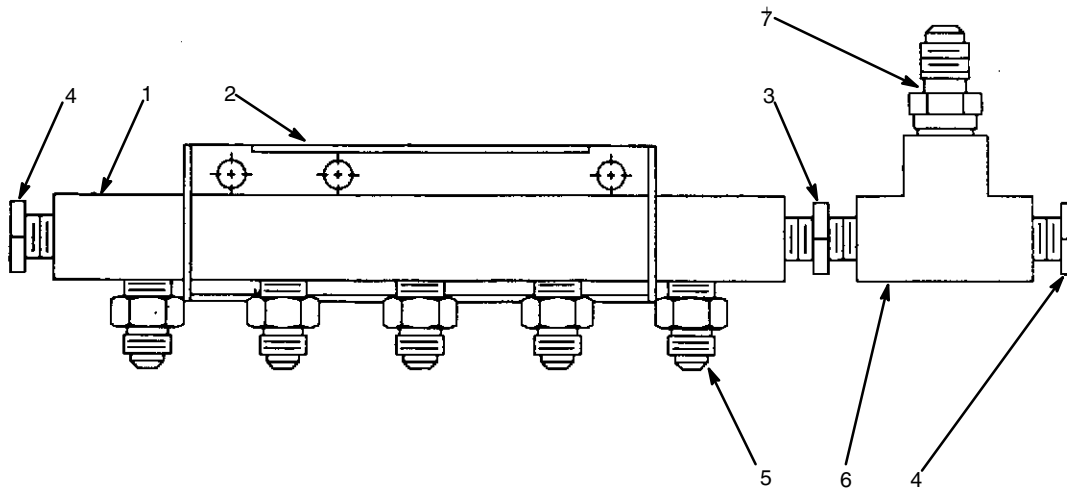

Item No.	Part No.	Name
	0145	CO ₂ Manifold and Bracket Ass'y
1	314886	Manifold
2	314887-044	Bracket, Manifold
3	183047	Fitting, 1/4 NPT
4	130066	Fitting, Plug
5	183301-100	Check Valve Ass'y (see Figure 5-4)
6	183060	Fitting Tee
7	770750-010	Fitting, 1/4 NPT By 7/16-20

FIGURE 24. MANIFOLD AND BRACKET ASS'Y (P/N 0145)

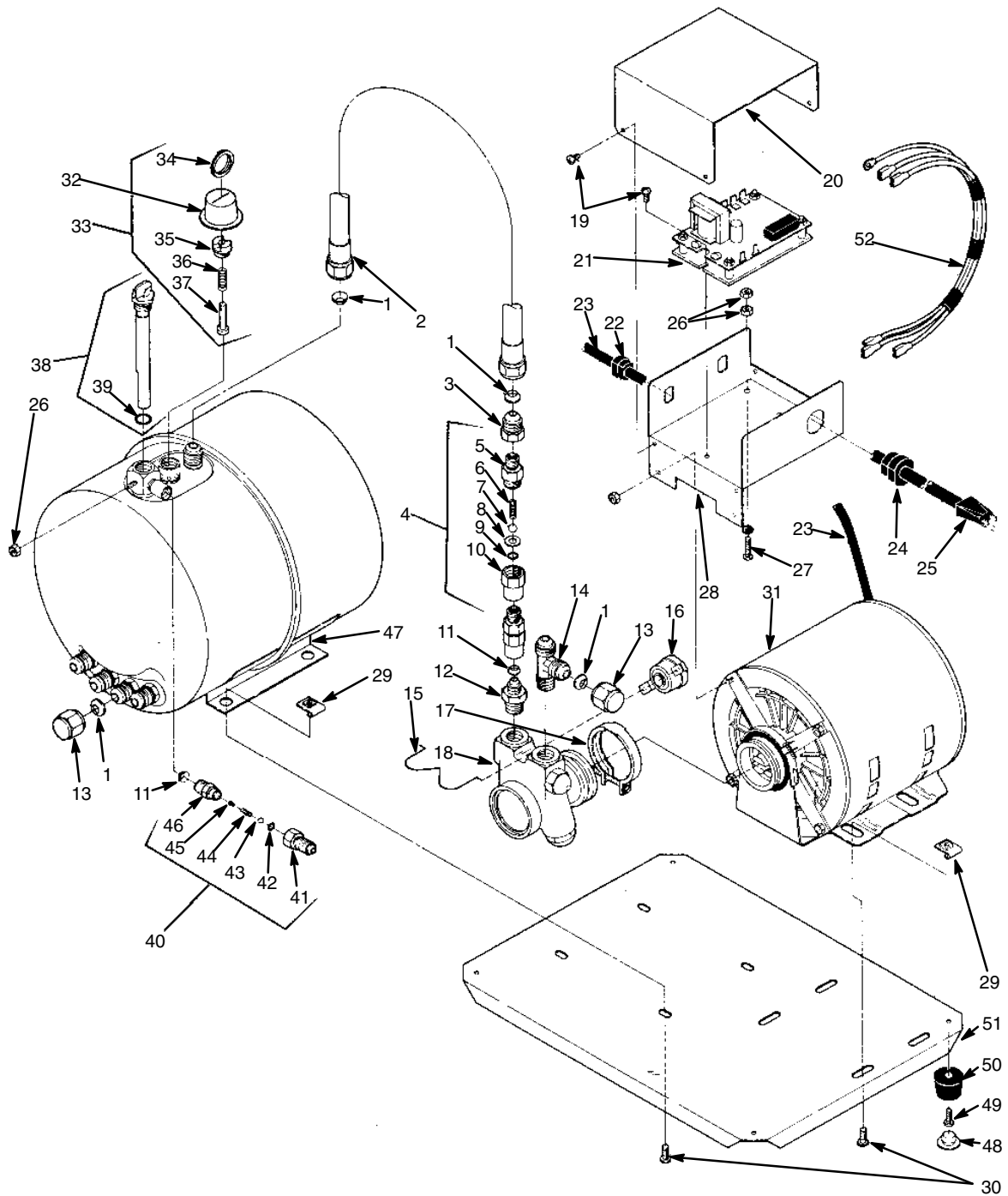

FIGURE 25. LARGE RESERVE CARBONATOR

LARGE RESERVE CARBONATOR

Item No.	Part No.	Name
	416424	Large Reserve Carbonator Ass'y, Low Profile, Domestic
	496424	Large Reserve Carbonator Ass'y, Low Profile, Export
1	311304	Tapered Gasket, Black
2	318027	Tube Ass'y. .375 I.D. By 13-in Long
3	770716-020	Fitting, 7/16-20 female by 5/8-18 male
4	311765-001	Check Valve Ass'y (includes 5-10)
5	317965	Retainer
6	312196	Spring
7	312419	Ball
8	312415	Washer, .300 I.D.
9	312418	Quad Ring, .239 I.D.
10	317963	Receptacle
11	178025-100	Tapered Gasket, White
12	311437	Fitting, 7/16-20 by 3/8-NPTF
13	770456	Cap Nut, 5/8-18
14	313001	Tee, 3/8 NPT by 5/8-18 by 5/8-18 Branch
15	318039	Clip, Thermostat
16	317989	Thermostat Control
17	187483	Clamp, Pump to Motor
18	312996	Pump, Water, 90-GPH
19	*320271	Thread Rolling, Screw, Phil Pan Hd, No. 6-32 by 3/8-in.
20	319438	Cover, Control Box
21	314015	Liquid Level Control, 120 VAC 60 HZ, Domestic
	197359	Liquid Level Control 230 VAC 50 HZ (Export)
22	395098	Strain Relief
23	309947	Cord Motor to Control Box
24	342134	Strain Relief
25	317277	Service Cord

Item No.	Part No.	Name
26	*200498-003	Hex Nut Keps, No. 8-32
27	*312578	Machine Screw, SI Rd Hd, No. 8-32 by 3/4-in long
28	319439	Control Box
29	311855	Speed Nut, J-type, 1/4-20
30	*318976	Machine Screw, SI Hex Washer Hd, 1/4-20 by 1/2-in long
31	315183	Motor, 115 VAC, 60 HZ (Domestic)
	199020	Motor, 230VAC 50HZ (Export)
32	317974	Water Reflector
33	318362-555	Relief Valve Ass'y (includes 35-38)
34	180343	Ring
35	318361	Bushing, Retaining
36	183249-032	Spring, Red
37	180352	Stem
38	318834-005	Probe, Level Control (includes 40)
39	180024	O-Ring, .424 I.D. by .103 C.S.
40	183310	Check Valve Ass'y (includes 42-47)
41	183309	Adapter
42	183294	Quad Ring, .145 I.D. by .070 C.S.
43	183296	Ball
44	183297	Spring
45	183298	Retainer, Spring
46	183295-100	Body
47	319436-900	Tank
48	330897	Button Plug
49	188087	Thread Cutting Screw, Phil Truss Hd, Chrome-pltd Steel, No. 10-24 by 1/2-in long.
50	188950	Foot
51	319444-011	Base
52	319921	Wire Harness

*Zinc Plated Steel unless Otherwise indicated

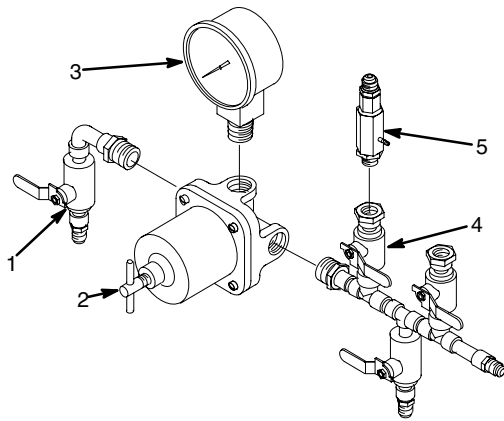

Item No.	Part No.	Name
	300914	Water Manifold Ass'y
1	0191	Manifold Ass'y with Shut-Off Valve
2	300922	Water Pressure Regulator
3	301102	Gauge, 100 PSI
4	0190	Manifold Ass'y with Shut-Off Valve
5	0881	Check Valve, Double Vented

FIGURE 26. WATER MANIFOLD ASS'Y (P/N 300914-000)

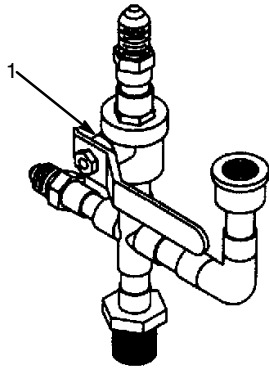

Item No.	Part No.	Name
	0193	Water Manifold Ass'y
1	300882	Shut-Off ValveShut-Off Valve

FIGURE 27. WATER OUTLET VALVE ASS'Y (P/N 0193)

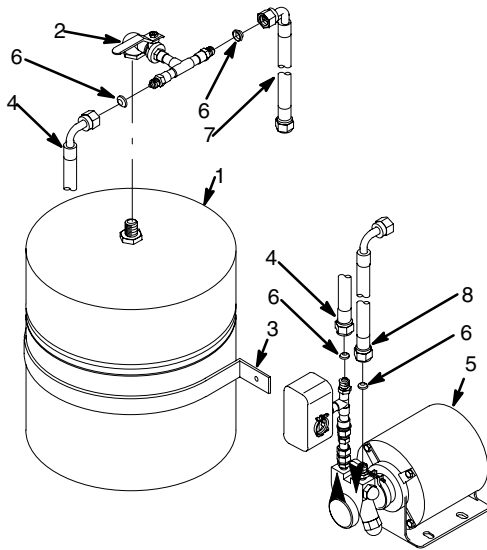

Item No.	Part No.	Name
	300915	Water Pressure Booster Kit Ass'y, Domestic
	0515	Water Pressure Booster Kit Ass'y, Export
1	300984	Water Tank, 100 PSI
2	0200	Shut-Off Valve Assembly
3	300893	Strap, Surge Tank
4	300890	Tube Assembly, .375 I.D. By 14" Long
5	0401	Pump and Motor Assembly, Domesitic (see Figure 5-13)
	0514	Pump and Motor Ass'y Export (see Figure 5-13)
6	311304	Tapered Gasket, Black
7	0782	Tube Assembly, .375 I.D. By 58" Long
8	1588	Tube Ass'y, .375 I.D. By 74" Long

FIGURE 28. OPTIONAL WATER PRESSURE BOOSTER KIT

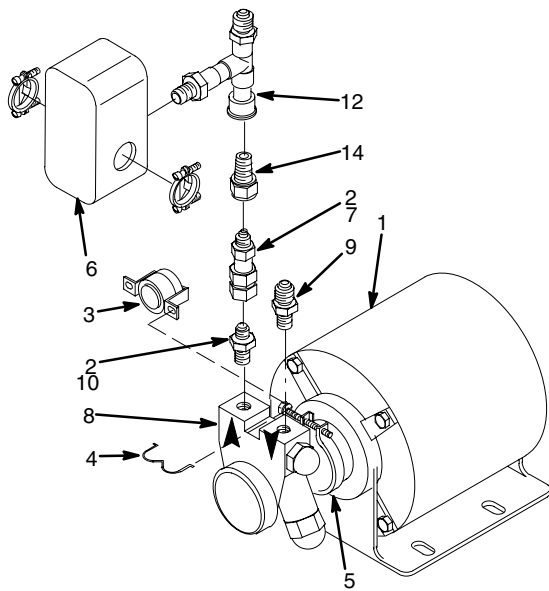

Item No.	Part No.	Name
1	315183	Motor, 115V. 60 HZ, Domestic
	320626	Motor, 230V. 50 HZ, Export
2	178025-100	Tapered Gasket, White
3	0629	Thermostat
4	318039	Clip
5	187483	Clamp, Pump to Motor
6	300888	Pressure Switch
7	311764-001	Check Valve Assembly (see Figure 5-14)
8	312996	Pump, 90 GPH
9	311412	Fitting, 3/8 NPT By 5/8-18
10	311437	Fitting, 3/8 NPT By 7/16-20
11	0877	Cord Domestic (not shown)
	0633	Cord, Export (not shown)
12	0491	Tube Assembly
13	0630	Cord (not shown)
14	320640	Fitting, 1/4 NPT By 7/16-20
15	188386	Machine Screw, SL Pan HD, NO. 10-32 By 1/2" Long (not shown)

FIGURE 29. PUMP AND MOTOR ASS'Y

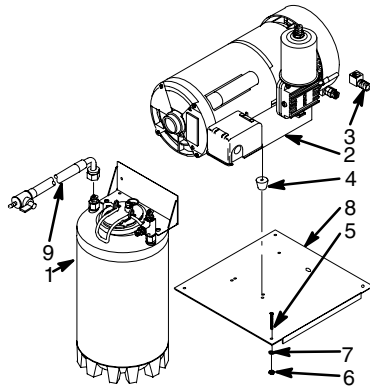

Item No.	Part No.	Name
1	111417	Air Tank
2	1111418-011	Compressor, Air
3	183068	Elbow Fitting, 1/4 NPT
4	188950	Rubber Feet
5	041602	Machine Screws, SL Fil HD, Stainless Steel No. 10-24
6	*398024-603	Nut, No. 10-24
7	1300	Washer, Stainless Steel, .229 I.D.
8	0497	Plate Mounting
9	0674	Drain Tube Ass'y

*Zinc Plated Steel Unless Otherwise Indicated.

FIGURE 30. OPTIONAL COMPRESSOR KIT

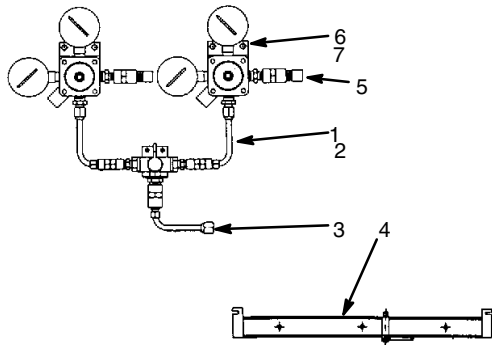

Item No.	Part No.	Name
1	0650	CO ₂ Regulator Ass'y (see Figure 5-16)
2	178025-100	Tapered Gasket, White
3	183061	Fitting, 1/4 NPT By 7/16-20
4	0671	Bracket, CO ₂ Cylinder
5	300933	Tube Ass'y, Hi-Pressure
6	398022-040	Machine Screw, SL RD, HD, Stainless Steel, NO. 10-24 By 5/8" Long
7	398024-603	Hex Nut, NO. 10-24

FIGURE 31. OPTIONAL PRIMARY CO₂ REGULATOR ASS'Y KIT (P/N 0708) FOR TWO 50-POUND CO₂ CYLINDERS

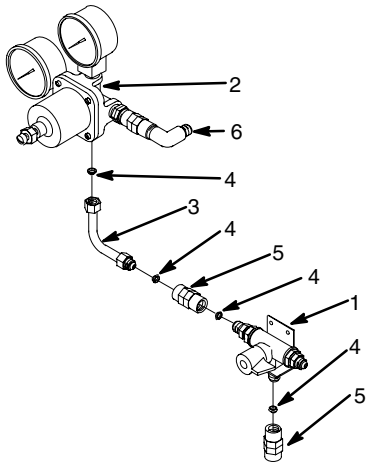

FIGURE 32. REGULATOR ASS'Y, HI-PRESSURE (P/N 0650)

Item No.	Part No.	Name
1	311904	Changeover Valve
2	0606	Regulator Ass'y (see Figure 5-17)
3	176065	Fitting, Swivel, 7/16-20
4	178025-100	Tapered Gasket, White
5	310822	Fitting, 7/16-20
6	176168-100	Fitting, 1/4 NPT By 7/16-20

*zinc Plated Steel Unless Otherwise Indicated.

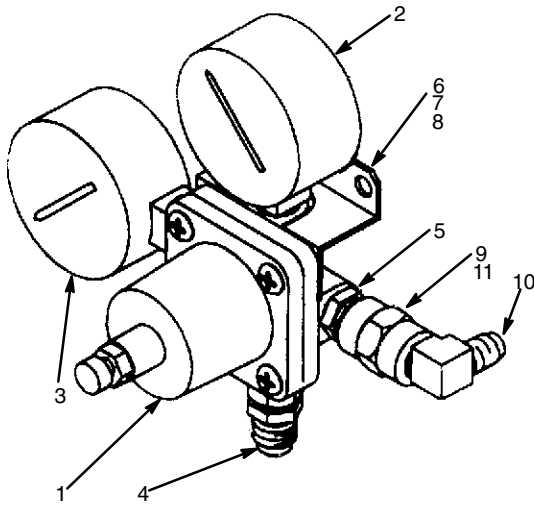

FIGURE 33. REGULATOR ASS'Y (P/N 0606)

Item No.	Part No.	Name
1	183586	Regulator ass'y (see Figure 5-6)
2	183285	Gauge, 160 PSI
3	183267	Gauge, 1800 PSI
4	183061	Fitting, 1/4 NPT By 7/16-20
5	183334	Fitting 1/4 NPT By 7/16-20
6	183317	Bracket, Regulator
7	*183040	Machine Screw, Phil Fil HD, No. 10-32 By 7/8" Long
8	*321811	Hex Nut, NO. 10-32
9	176168-100	Fitting 1/4 NPT By 7/16-20
10	187485	Fitting, 1/4 NPT By 7/16-20
11	178025-100	Tapered Gasket, White

*Zinc Plated Steel Unless Otherwise Indicated.

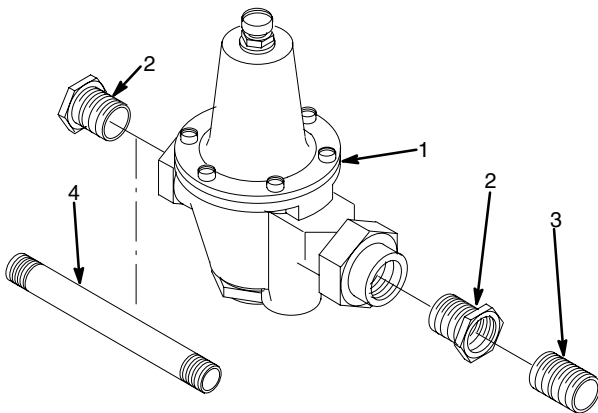

FIGURE 34. OPTIONAL WATER PRESSURE REGULATOR KIT (P/N 300919-000)

Item No.	Part No.	Name
1	317928	Regulator
2	0711	Fitting
3	0712	Fitting
4	1301	Fitting, 1/2 NPT

WARRANTY

IMI Cornelius Inc. warrants that all equipment and parts are free from defects in material and workmanship under normal use and service. For a copy of the warranty applicable to your Cornelius, Remcor or Wilshire product, in your country, please write, fax or telephone the IMI Cornelius office nearest you. Please provide the equipment model number, serial number and the date of purchase.

IMI Cornelius Offices

AUSTRALIA • P.O. 210, • RIVERWOOD, • NSW 2210, AUSTRALIA • (61) 2 533 3122 • FAX (61) 2 534 2166
AUSTRIA • AM LANGEN FELDE 32 • A-1222 • VIENNA, AUSTRIA • (43) 1 233 520 • FAX (43) 1-2335-2930
BELGIUM • BOSKAPELLEI 122 • B-2930 BRAASCHAAT, BELGIUM • (32) 3 664 0552 • FAX (32) 3 665 2307
BRAZIL • RUA ITAOCARA 97 • TOMAS COELHO • RIO DE JANEIRO, BRAZIL • (55) 21 591 7150 • FAX (55) 21 593 1829
ENGLAND • TYTHING ROAD ALCESTER • WARWICKSHIRE, B49 6 EU, ENGLAND • (44) 789 763 101 • FAX (44) 789 763 644
FRANCE • 71 ROUTE DE ST. DENIS • F-95170 DEUIL LA BARRE • PARIS, FRANCE • (33) 1 34 28 6200 • FAX (33) 1 34 28 6201
GERMANY • CARL LEVERKUS STRASSE 15 • D-4018 LANGENFELD, GERMANY • (49) 2173 7930 • FAX (49) 2173 77 438
GREECE • 488 MESSOGION AVENUE • AGIA PARASKEVI • 153 42 • ATHENS, GREECE • (30) 1 600 1073 • FAX (30) 1 601 2491
HONG KONG • 1104 TAIKOTSUI CENTRE • 11-15 KOK CHEUNG ST • TAIKOKTSUE, HONG KONG • (852) 789 9882 • FAX (852) 391 6222
ITALY • VIA PELLIZZARI 11 • I-20059 • VIMARCATI, ITALY • (39) 39 608 0817 • FAX (39) 39 608 0814
NEW ZEALAND • 20 LANSFORD CRES. • P.O. BOX 19-044 AVONDALE • AUCKLAND 7, NEW ZEALAND • (64) 9 8200 357 • FAX (64) 9 8200 361
SINGAPORE • 16 TUAS STREET • SINGAPORE 2263 • (65) 862 5542 • FAX (65) 862 5604
SPAIN • POLIGONO INDUSTRIAL • RIERA DEL FONOLLAR • E-08830 SANT BOI DE LLOBREGAT • BARCELONA, SPAIN • (34) 3 640 2839 • FAX (34) 3 654 3379
USA • ONE CORNELIUS PLACE • ANOKA, MINNESOTA • (612) 421-6120 • FAX (612) 422-3255

LD004
4/21/98